

Plessey Semiconductors Ltd

EPIC SENSOR APPLICATIONS GUIDEBOOK

Contents

| | | |
|--------|---|-----|
| 1 | Introduction..... | 2 |
| 2 | Overview | 3 |
| 2.1 | Contact and near contact applications overview | 9 |
| 2.2 | EPIC Contact demonstrators..... | 12 |
| 2.3 | <i>imPulse</i> + Demonstrator overview..... | 14 |
| 2.4 | <i>imPulse</i> ++ demonstrator overview | 15 |
| 2.5 | Driver Health overview | 18 |
| 2.6 | Identification of ECG Signature/Security demo overview..... | 21 |
| 3 | Applications | 22 |
| 3.1 | Introduction | 22 |
| 3.2 | Tele Health | 22 |
| 3.2.2 | Sports Watch | 28 |
| 3.2.3 | Smart phone | 29 |
| 3.2.4 | Single arm ECG measurement..... | 30 |
| 3.2.5 | Hand rail scales | 34 |
| 3.3 | Driver Health..... | 35 |
| 3.3.1 | Introduction | 35 |
| 3.3.2 | The PS25502PAD | 36 |
| 3.3.3 | Operation | 37 |
| 3.3.4 | DRL..... | 40 |
| 3.4 | Identification ECG Signature/Security | 45 |
| 3.5 | Remote Sensing..... | 47 |
| 3.5.1 | <i>imPart</i> | 47 |
| 4 | Appendix A | 48 |
| 4.1 | Sensor Options..... | 49 |
| 4.2 | Datasheets | 61 |
| 4.2.1 | App Boards for EPIC sensor PS25201A/ PS25012A1,B1 | 61 |
| 4.2.2 | App Boards for EPIC sensor PS25202/ PS252012A2,B2 | 63 |
| 4.2.3 | App Boards for EPIC sensor PS25012A3,B3..... | 65 |
| 4.2.4 | App Boards for EPIC sensor PS25204/ PS25012A4,B4 | 67 |
| 4.2.5 | App Boards for EPIC sensor PS25401A/ PS25014A1,B1 | 69 |
| 4.2.6 | App Boards for EPIC sensor PS25402/ PS25014A2,B2 | 71 |
| 4.2.7 | EPIC Ultra High Impedance ECG Sensor Advance Info PS25101 | 73 |
| 4.2.8 | EPIC Ultra High Impedance ECG Sensor Advance Info PS25102 | 76 |
| 4.2.9 | EPIC Ultra High Impedance Electrophysiological Sensor/ PS25201A/B | 79 |
| 4.2.10 | EPIC Ultra High Impedance ECG Sensor Advance Info PS25202 | 82 |
| 4.2.11 | EPIC Ultra High Impedance Electrophysiological Sensor/ PS25203B | 85 |
| 4.2.12 | EPIC Ultra High Impedance ECG Sensor Advance Info PS25204 | 89 |
| 4.2.13 | EPIC Ultra High Impedance ECG Sensor Advance Info PS25251 | 94 |
| 4.2.14 | EPIC Ultra High Impedance Movement Sensor/ PS25401A/B | 98 |
| 4.2.15 | EPIC Ultra High Impedance Movement Sensor Advance Information..... | 101 |
| 4.2.16 | EPIC Ultra High Impedance Movement Sensor/PS25451 Advance Info..... | 104 |
| 5 | Appendix B | 107 |
| 5.1 | EPIC Demo Kit | 108 |
| 5.2 | Installation of EPS Evaluation Software | 112 |
| 6 | Appendix C | 113 |
| 6.1 | FAQ | 114 |
| 7 | Appendix D..... | 116 |
| 7.1 | Contact Information | 117 |
| 7.1.1 | Technical Support..... | 117 |
| 7.1.2 | Plessey Locations..... | 117 |
| 7.1.3 | Distributors & Reps..... | 118 |

1 Introduction

Purpose of the EPIC sensor applications Handbook

Plessey Semiconductors have created a range of sensors that can be used for the detection of very small variations in an electric field. The core of the sensor is an Electric Potential Integrated Circuit (EPIC).

This application handbook collates all the technical material produced by Plessey Semiconductors related to the EPIC sensor, and its many uses. It forms a useful single point reference source to assist the development of the EPIC sensors in new applications.

The handbook takes the reader through an overview of the principles behind the EPIC, how it can be used in many different applications and includes the datasheets and instruction manuals for various sensors, demo boards and demonstrators. The latter are available from Plessey Semiconductors and can be the starting point for any new development.

2 Overview

What is EPIC?

Summary

- EPIC measures changes in electric potential, that could be:
 - The earth's natural electric field
 - ~100v / vertical meter
 - The environment electric field
 - 50/60Hz mains frequency
 - Biometric electric field
 - ECG / EMG / EOG / EEG
 - An induced electric field

EPIC is an acronym for "Electric Potential Integrated Circuit" but the term has become synonymous with the integrated circuit technology, the sensor itself, and, in a wider context, the physical principles of operation of the device within a system.

EPIC is a noncontact electrometer, meaning that there is no direct DC path from the outside world to the sensor input, a condition that is somewhat analogous to the gate electrode of an MOS transistor. The electrode is protected by a capping layer of dielectric material to ensure that the electrode is isolated from the body being measured. The device is AC coupled with a lower corner frequency (-3dB) of a few tens of MHz and an upper corner frequency above 200 MHz. This response is adjustable and can be tailored to suit a particular application. Such an electrometer cannot be DC coupled because the Earth's electric field close to the surface is $\approx 100\text{-}150$ V/m.

In single-ended mode the device can be used to read electric potential; used in differential mode it can measure the local electric field; or it can be deployed in arrays to provide spatial potential mapping (locating a conducting or dielectric material placed within free space).

Figure 1 shows a basic block diagram of the EPIC sensor [1]. The size of the electrode is somewhat arbitrary and depends on the input capacitance required for a particular application. For bodies placed close to the electrode, the electrode's size is important and the device operation can be understood in terms of capacitive coupling. For devices that are several meters away, the coupling capacitance is defined only by the self-capacitance of the electrode and the device's response is largely a function of the input impedance as it interacts with the field. This is rather counterintuitive but is a function of the very small amount of energy that EPIC takes from the field in active mode.

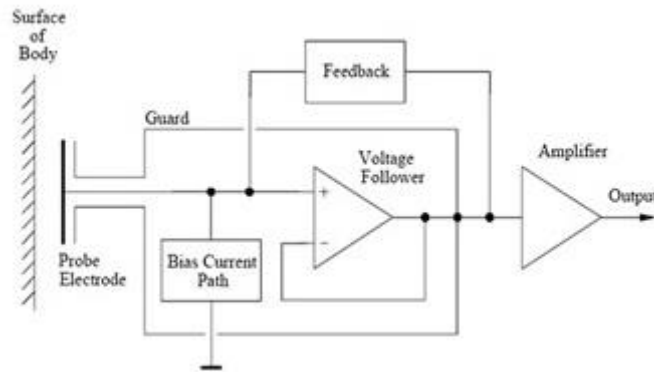

Figure 1

The input resistance to the device can be boosted by using bootstrapping techniques while the input capacitance can be reduced using guarding techniques. The input capacitance can be driven as low as 10^{-17}F with the input resistance being boosted to values up to around $10^{15}\Omega$, thus keeping the interaction with the target field to an absolute minimum and ensuring that all currents are small displacement currents only.

A better understanding of the feedback mechanisms can be obtained by considering the input buffer of the amplifier and its associated impedances as shown in [Figure 2](#). The resistors R_{G1} and R_{G2} are used to set the gain of the first stage, which is nominally unity. C_{in} and R_{in} represent the input capacitance and resistance native to the amplifier, respectively, and include any parasitic components due to layout or substrate issues. The capacitor C_{ext} models the capacitive coupling to the measurement target.

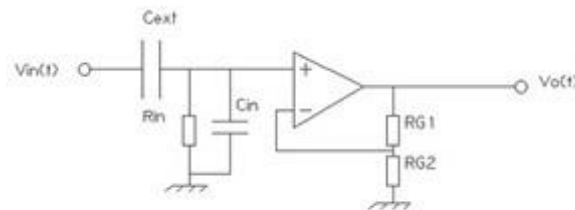

Figure 2

For close coupling ($C_{ext} \gg C_{in}$) this is usually defined as

$$C_{ext} = \frac{\epsilon_0 \epsilon_r a}{d}$$

where:

a = the equivalent shared electrode/target area

d = the distance between target and sensor

ϵ_0 = the permittivity of free space

ϵ_r = the relative permittivity of the dielectric in which the sensor is operating

For loose coupling ($C_{ext} \ll C_{in}$) we have the limiting case (self-capacitance) shown as

$$C_{ext} = 8 \epsilon_0 \epsilon_r r$$

Where r is the diameter of the sensor plate.

Analysis of the circuit shows us that we have a classic single-pole transfer function shown as

$$C_{ext} = 8 \epsilon_o \epsilon_r r$$

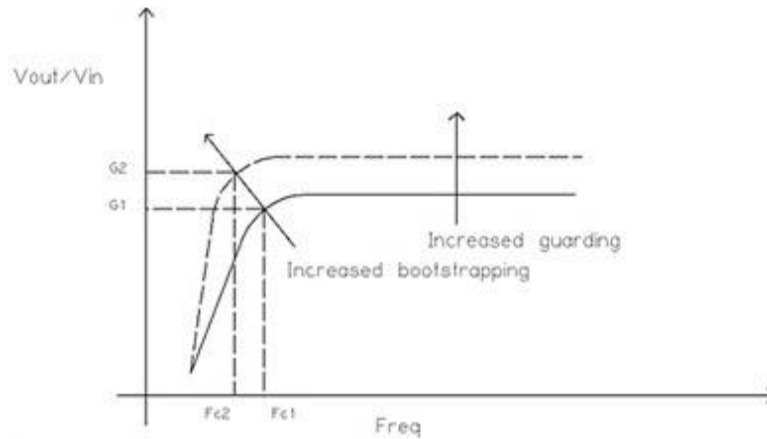

Figure 3 - Bode plot for the transfer function of Equation 3

The corner frequency (Fc1) can be expressed as

$$Fc1 = \frac{1}{2\pi(C_{ext} + C_{in})R_{in}}$$

Application Areas

Applications can be divided between Non-contact, and Contact or near contact.

Non contact applications include:

- Movement sensing
 - Security
 - Automatic switching
- Proximity sensing
 - Non-contact switching
- Gesture recognition
 - Appliance control
 - Cursor control

Contact or near contact application include:

- Health monitoring
- Sports monitoring
- Driver well being
- Patient well being

Non-contact applications theory

EPIC can be used in non-contact applications to sense

- Field disturbance
- Monitoring charge
- Interaction with ambient field.

Field disturbance

– The earth's electric field is ~100V per vertical metre

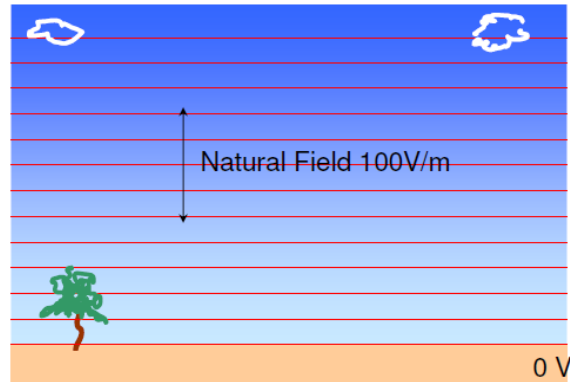

- A person moving within that field affects the field
- EPIC can measure the disturbance

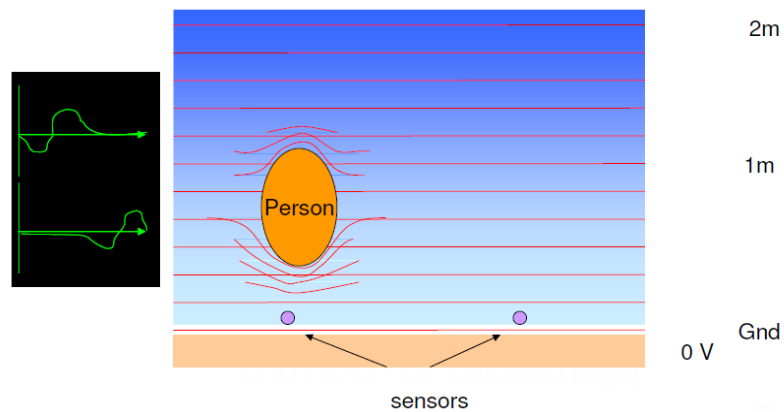

Moving charge

- A charged person or object will change the e-field when moving
- EPIC can measure the disturbance

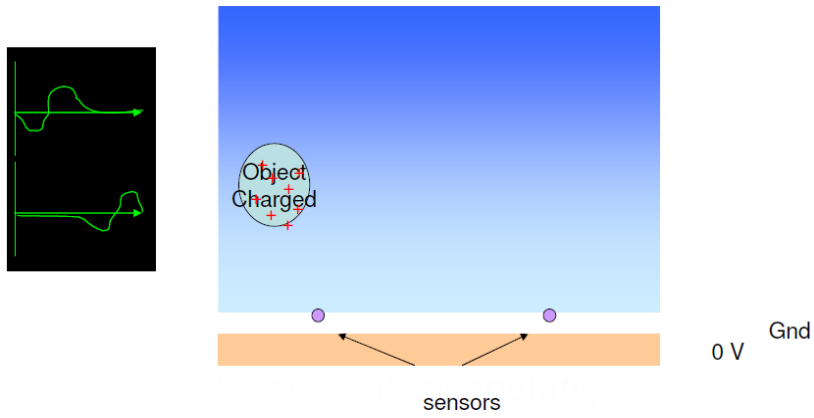

Interaction with ambient ac field

- Two sensors monitoring e.g. 50Hz mains field

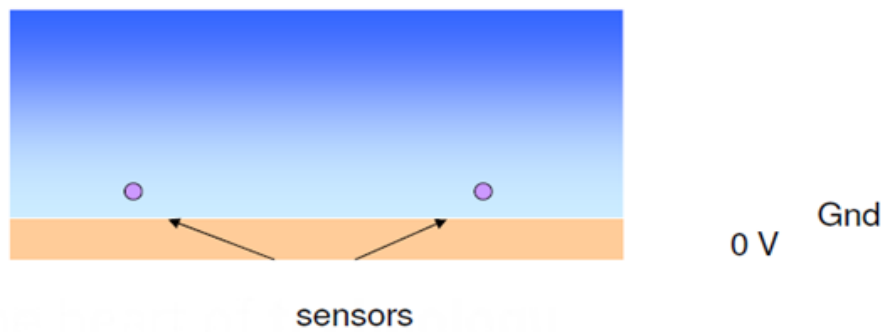
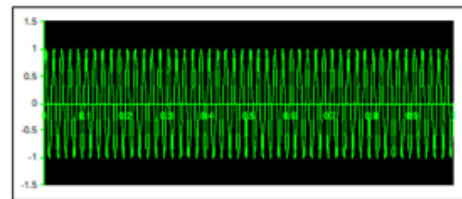
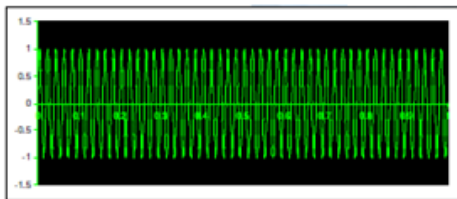

– Moving hand near one sensor changes relative amplitudes

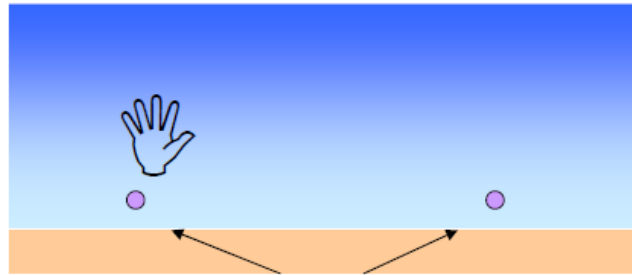
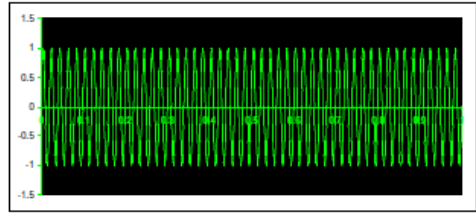
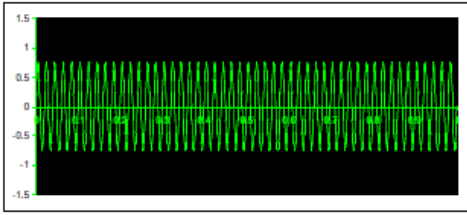

sensors

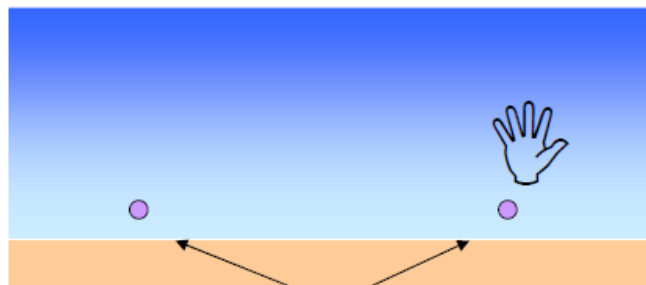
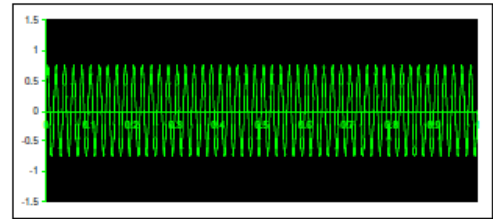
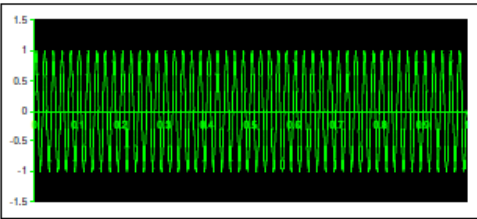

sensors

2.1 Contact and near contact applications overview

Contact mode

- Surface body electrophysiology – ECG, EMG, EEG, EOG
- Long term monitoring - no skin irritation, may be worn indefinitely
- Telehealth - ease of use, no surface preparation required
- Rehabilitation - long term acquisition of control signals
- Assistive technologies - acquisition of multiple EMG signal

Near contact mode

- Occupancy monitoring – movement
- Vital signs – breathing/cardiac function

Introduction

A great amount of interest has been generated within the medical community where the primary focus is on using EPIC for surface body electrode physiology applications such as electrocardiograph (ECG), electromyograph (EMG), electroencephalograph (EEG), and electrooculargraph (EOG).

The EPIC sensor can be used, for example, as a replacement technology for traditional wet-electrode ECG pads, because it requires neither gels nor other contact-enhancing substances. When the EPIC sensor is placed on (or in close proximity to) the patient, an ECG signal can be recovered. The sensor is capable of both simple 'monitoring' ECG as well as making more exacting clinical diagnostic measurements. In the latter application it can be used as a replacement for the traditional twelve-lead ECG, in which electrodes are placed on the limbs and torso (each pair of electrodes is called a lead and each lead measures the electrical activity of the heart from a slightly different perspective) to achieve a clearer picture of how the patient's heart is working. An array of EPIC sensors placed on the chest can be used to recreate the lead required with resolution as good as or better than that achieved using traditional systems. Figure 5 shows a comparison between the results using EPIC and using traditional wet electrodes for leads II and aVL [2]. These two leads are important in the diagnosis of conditions such as coronary artery occlusion.



FIGURE 5. ECG READOUTS SHOWING THE RESULTS USING EPIC (TOP) VS. TRADITIONAL WET ELECTRODE ECG (BOTTOM)

The sensor can also be used for recovering other physiological signals such as those caused by the electrical activity of the eye muscles as one looks left, right, up, or down. These signals have unique signatures; an EOG can be used to track the position of the eyes and therefore produce targeting information for military and gaming applications, for example. Perhaps the most exciting application in the medical field is that of electroencephalography (EEG) where the electrical activity of the brain is recorded. Application of the EPIC sensor to this field is still in its infancy but the potential ability to record identifiable signals against known thought patterns opens up possibilities that currently only exist in science fiction.

Identification ECG Signature/ Security Applications

Because of EPIC's mode of operation, it can be used to detect any disturbance in the local electric field at distances of up to several tens of meters (This could be dramatically reduced depending on environmental conditions). The human body, because it acts as a large container of conducting/polarizable material, causes a large perturbation in the electric field and so presents an easily detectable target for the sensor. Sitting a few meters away from the sensor, one has only to raise the sole of one's foot to create a strong signal. Arrays of sensors can be used to provide spatial resolution and therefore the location of a target. Such arrays can also distinguish between humans and quadrupeds because the time signature of the response is a direct function of cadence. Such a system of sensors could perhaps be used for border security in remote areas.

Other Applications

Man-machine Interface

The ability of EPIC to resolve signals unique to various muscles or groups of muscles presents opportunities for improved man-machine interaction. For example, a quadriplegic who currently depends on either a unicorn stick or a suck/blow tube to issue commands to equipment within his or her local environment could achieve a faster and more efficient interaction using EPIC for eye tracking and detection of activity in any muscle groups still under voluntary control. Alternatively, because EPIC can assign a unique signature to the use of certain muscle groups, it opens up many possibilities for interfacing with and controlling prosthetic limbs.

Microscopy

EPIC is also a useful tool in the microscopic domain. Small sensors scanning a microchip, for example, can show areas of high or low potential, allowing the user to map the current distribution within metal tracks and other circuit elements. Faults in dielectric materials can also be detected either by passive means (by detecting piezoelectric effects) or by identifying leakage paths in an active circuit.

Recently a $\approx 6 \mu\text{m}$ sensor has been used to reveal a human fingerprint left on an insulating PTFE material (Figure 6) and to characterize its decay over time [3]. The advantage to the forensic scientist of being able to date a fingerprint is obvious. The technique is non-destructive and leaves no chemical residue, which means that DNA samples can be taken at a later date.

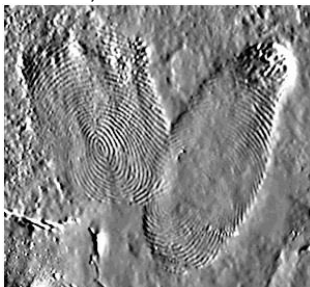

2.2 EPIC Contact demonstrators

Plessey Semiconductors have developed demonstrators that can be used as standalone products, or can be incorporated into new system designs. They are:

- imPulse* ECG monitor
- Sports watch ECG monitor
- Drivers non contact ECG seat
- Identification of ECG Signature/Security

imPulse demonstrator overview

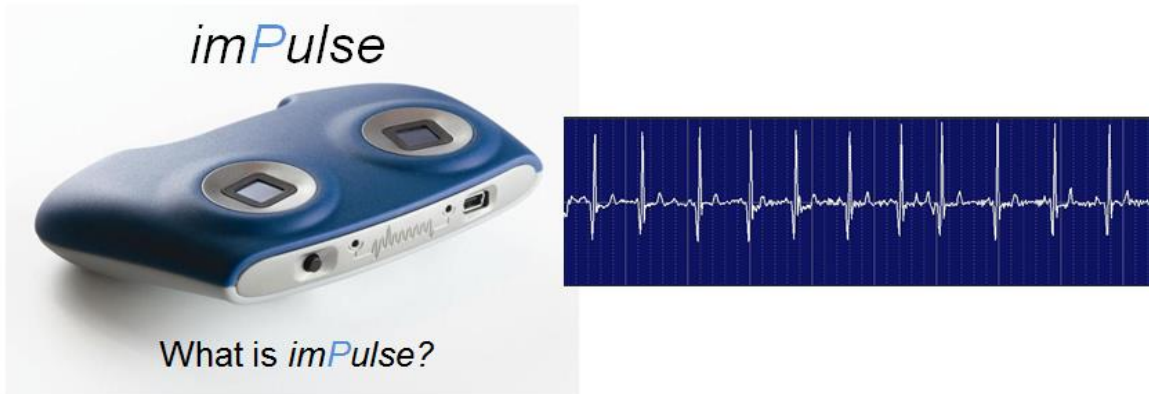

The *imPulse* takes a capacitively coupled lead one ECG, right arm (negative electrode) to left arm (positive electrode)

Transmitted via Bluetooth to a smartphone for display, storage and transmission to the cloud

Features:

- Hand held unit for home ECG monitoring
- Two PS25201B sensors. (in all future models it will be the PS25251)
- Bluetooth – runs with Android phone app
 - Display ECG
 - Count heart rate
 - Flag ECG abnormalities

Smartphone display

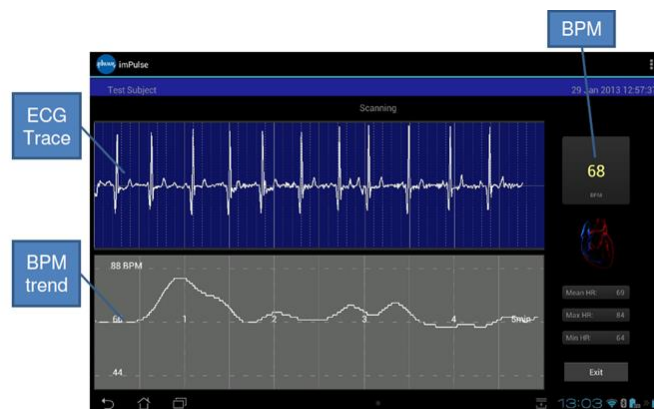

Among the applications that Plessey envisions for its *imPulse* unit, two stand out. One is as a screening device for use by clinicians. Full 12-lead ECGs are time-consuming, expensive, and are a drain on health service resources. While a single-lead ECG measurement can never provide the full information of a 12-lead ECG, it can most certainly be a key tool in detecting common heart complaints such as arrhythmias, atrial fibrillation (AF), and the effects of myocardial infarction. AF is often an early warning of an impending stroke, which at the very least will result in long recovery periods including hospitalization, and, at worst, long-term severe disability or death. Being able to provide a quick and simple test for these conditions will enable those who urgently need the attentions of cardiologist to be prioritized, saving not only resources, but much suffering and ultimately, lives.

The second application area is a home health screening device. The situation can range from an individual wanting to measure well-being for fitness reasons, to serious athletes wanting to measure ECG parameters as part of a training program, to regular health monitoring of those with cardiac problems who would otherwise need to be hospitalized. While this product is not intended to replace regular doctor visits, it can supplement the visits with the ability to record a short trace and have it automatically transmitted to a healthcare provider for software-based analysis on a daily basis. This can have a major impact on the ability for the sick and elderly to preserve their independence, whole not being subjected to an increased risk of preventable heart-related illness.

Although the *imPulse* is primarily designed for measuring an ECG from the hands, it can also be place on the user's chest, and, in the right conditions, can even measure ECG through clothing. The *imPulse* will soon be qualified and approved for use in the UK and US.

2.3 *imPulse* + Demonstrator overview

Space holder

2.4 *imPulse* ++ demonstrator overview

Space holder

Sports Watch overview

EPIC for Sports & Fitness

- ECG for workout feedback

- Gives ECG feedback during breaks in training simply by touching the two sensors with the opposite hand or another band on the opposite wrist

- Lead one ECG would then be obtained, recorded and analysed local with commercially available algorithms or in “The Cloud” for feedback of potential problems

- Workout Definition

- Tailoring your next workout based on your current ECG trace information



Smartphone display



Sports Watch Demonstrator

Bluetooth watch demonstrator

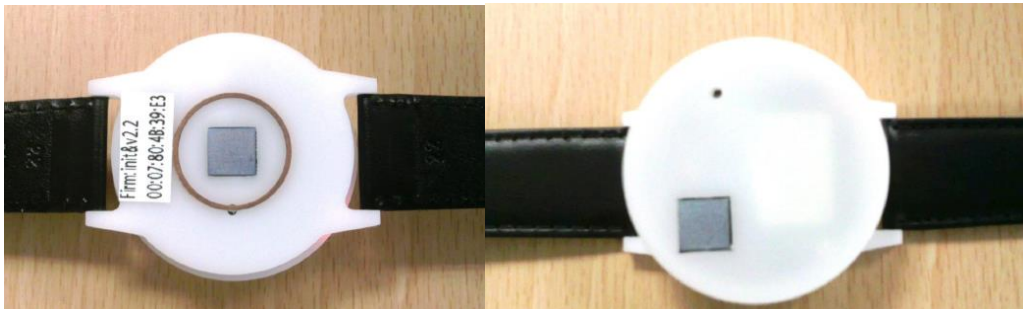

- Wrist mounted device for sports ECG monitoring
- Two PS25201B sensors
 - One in permanent wrist contact
 - Second touched by finger to record ECG
- Bluetooth connectivity as for IMPLUSE demonstrator

ECG Wristwatch with Bluetooth

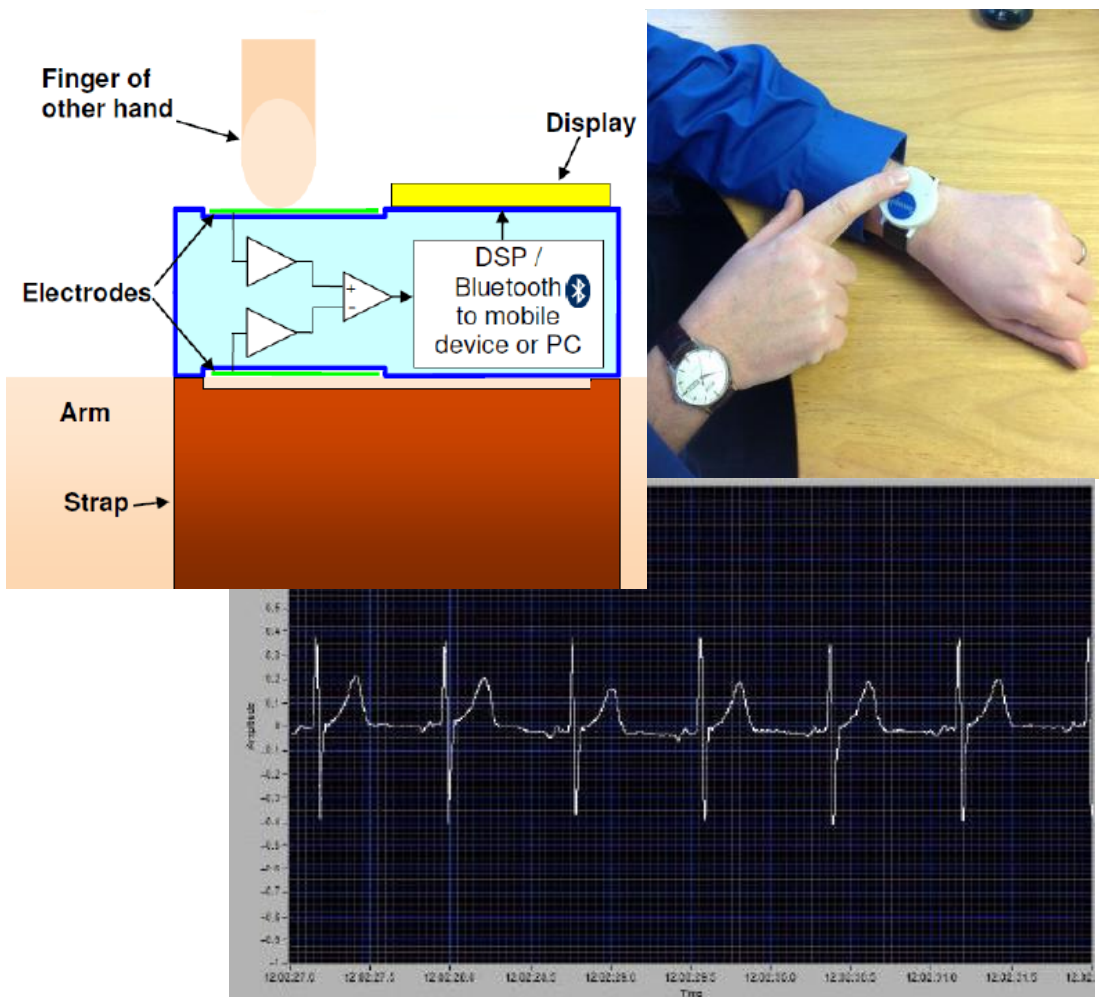

2.5 Driver Health overview

Non contact ECG

- EPIC can be used to sense ECG through clothes due to its patented capacitive coupled sensing technology
- This makes possible the use with sports tops and chest straps to give an ECG (not just heart rate like other systems)
- Sensors can be embedded into seatbacks to sense ECG for:
 - Automotive applications
 - Gym recumbent bike systems
 - Array of sensors embedded in to seat back
 - No direct connection to subject for ground
 - Capacitively coupled reference derived from sensor signals



ECG HRV analysis
Indication of sympathetic / parasympathetic
autonomous nervous system drift

Non-contact ECG sensing using EPIC

- Capacitive EPIC sensors can measure ECG without skin contact
- Capacitively coupled driven ground for noise reduction
 - Feeds back common mode signal to body in anti-phase

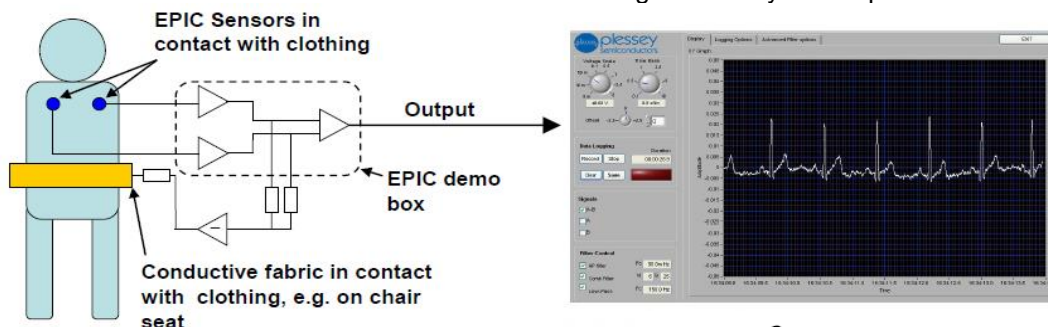

Why monitor driver health?

Prevention of accidents caused by:

- Driver Fatigue
- Serious health issues
 - Cardiac arrest
 - Stroke
 - Blackouts

Identification of stress

- Interface with other in-car technology to reduce stress levels



Driver Fatigue

- “Research shows that driver fatigue may be a contributory factor in up to 20% of road accidents, and up to one quarter of fatal and serious accidents”

Source: RoSPA – Road Safety Information, June 2011

- “Fatigue related impairment has been estimated to be a contributing factor in 30% to 40% of heavy truck collisions”

Source: AAA Foundation for Traffic Safety, 1985; National Transportation Safety Board, 1990

Other potential sources of data

Is this enough?

- Benefit of earlier warnings
- Accidents due to fatigue-related concentration lapses
- Microsleeps may be too late
- Other indicators:
 - Respiration rate
 - Body temperature
 - EEG – Alpha waves vs Beta waves
 - ECG
- The more data, the better the chance of accident prevention

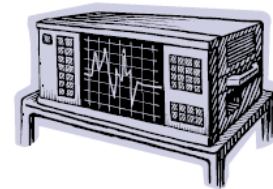

Existing methods of fatigue monitoring

- Timer (length of journey)
- Lane departure warning
- Head movement detection
- Blinking / eye-closure rate



ECG

- ElectroCardioGram (ECG) – Electrical activity of the heart muscle
- Heart rate
 - Studies show that Heart Rate Variability correlates with tiredness
- Heart health
- Measurement doesn't have to mean contact electrodes



Steering Wheel Application Example

Hidden system

- Sensors and ground plane operate through a variety of materials including leather and cotton
 - Operates through seat covering and clothes
- Movement artefacts reduced by good sensor positioning
- Further noise reduction by coupling driven ground to steering wheel

Car Seat Demonstrator

Driver well-being system

- 6 x PS25203C sensors and driven ground plane all mounted under seat cover fabric
- Best pair of sensors selected according to driver height
- Potential to detect drowsiness, cardiac problems etc.
- ECG HRV analysis
 - Indication of sympathetic / parasympathetic autonomous nervous system drift

Demonstration system

•Key features

- 6 sensors in seat pad, select best position for each driver
- 3 different electrode sizes
- Adjustable gain in active ground feedback loop
- Leather or cotton covering
- USB interface to PC
- Live data display or data recording for offline processing

Sensor array



Ground plane

Demonstration

- Demonstrated in moving vehicle
- Good signal quality with minimal signal processing
 - >95% of "R" peaks detected over 10 minute trial

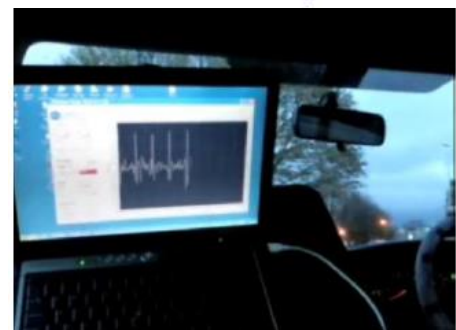

2.6 Identification of ECG Signature/Security demo overview

User Identification

- ECG is unique to each person.
- Identification can usually be achieved within 2 seconds with a 1 in 10 failure rate (false negative).
- Failure rates can be reduced to 1 in 100 at 6 seconds.
- If enrolled at 60bpm the additional errors at:
 - 120 bpm = 2.9%
 - 170 bpm = 11%
- Enrolling with high stress data:
97% accuracy can be achieved within 3 seconds.
- Biometric template can be continually enriched with stress data.

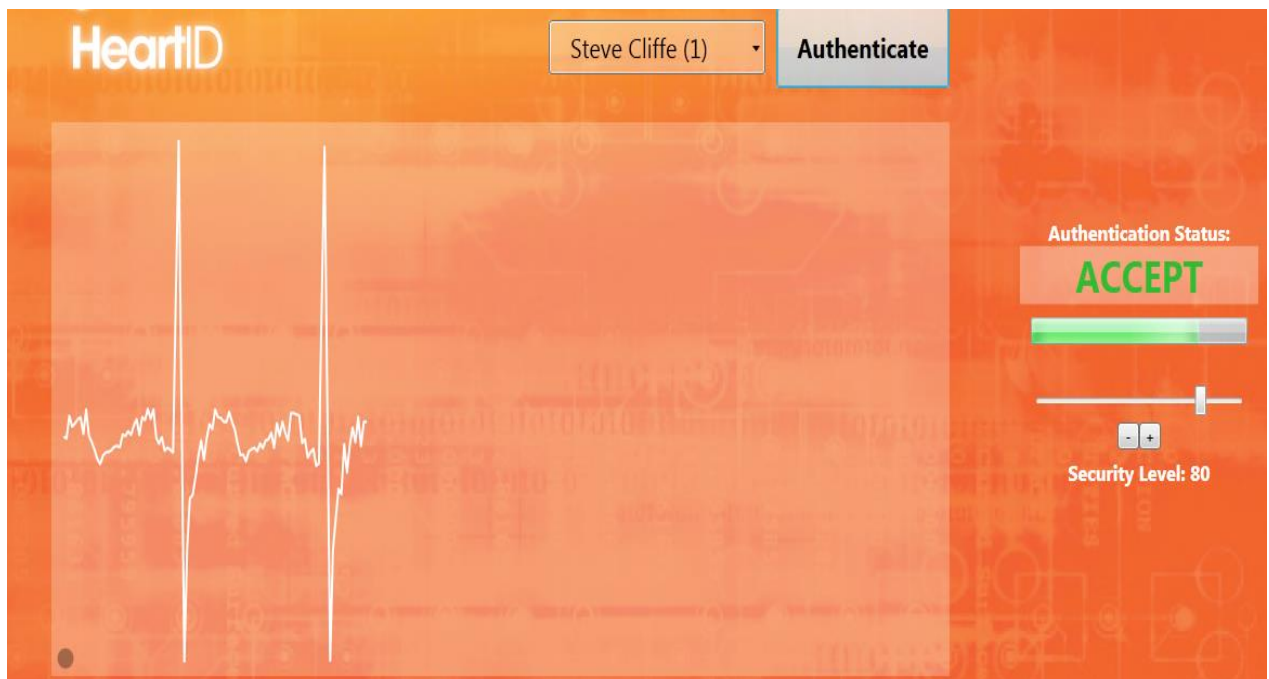
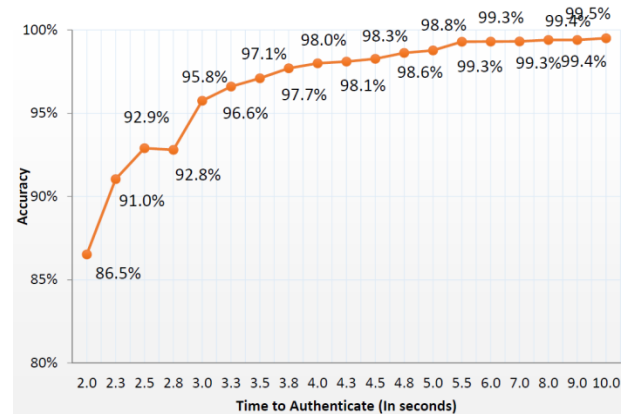

3 Applications

3.1 Introduction

This section includes detailed application notes and user manuals for various implementations that can use the EPIC sensor.

3.2 Tele Health

3.2.1.1 *imPulse*

With Health and Wellbeing so prominent in people's minds Plessey has developed a simple to use hand held ECG monitor. Utilising Plessey's disruptive Electric Potential sensing technology, to detect an ECG signal, all that is required is the simple placement of the thumbs on the sensors embedded in the demonstration unit (*imPulse*). This allows for a routine, quick, accurate recording of ECG signal outside of the medical environment and without the need for conductive gel or skin preparation.

The signal is transmitted using Bluetooth to a Smartphone or Tablet computer and displays the ECG trace along with heart rate readout. The trace can be either analysed locally or can be sent to "The Cloud" for analysis against commercially available algorithms.

3.2.1.1.1 *imPulse* Instruction Manual



Standard Components PS25503

- One PS25503 *imPulse* unit.
- Mini USB cable
- User guide

1.0 Introduction

The Plessey PS25503 *imPulse* unit is a hand held device capable of measuring a lead one (right arm minus left arm) ECG and transmitting the data via a Bluetooth link to an Android device. Custom software installed on the device can then display the ECG trace and perform some simple analysis (rate plus PVC detection). The device uses two Plessey PS25201 sensors to recover the ECG signals from the finger tips.

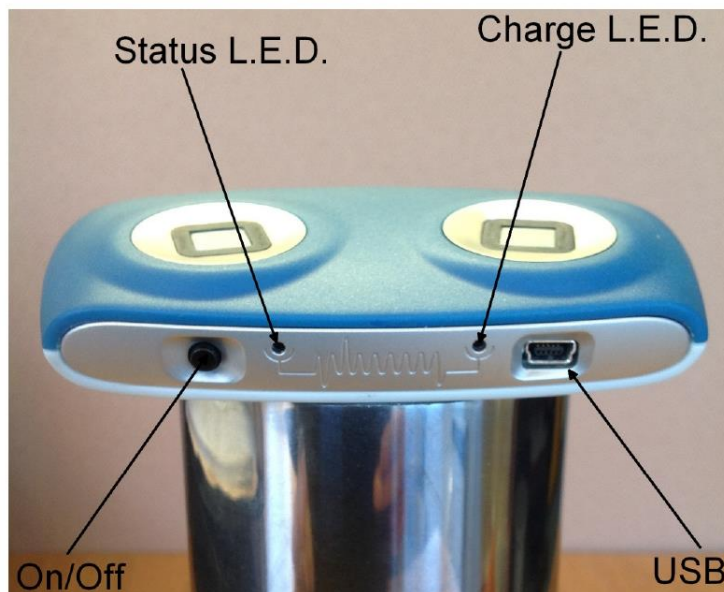
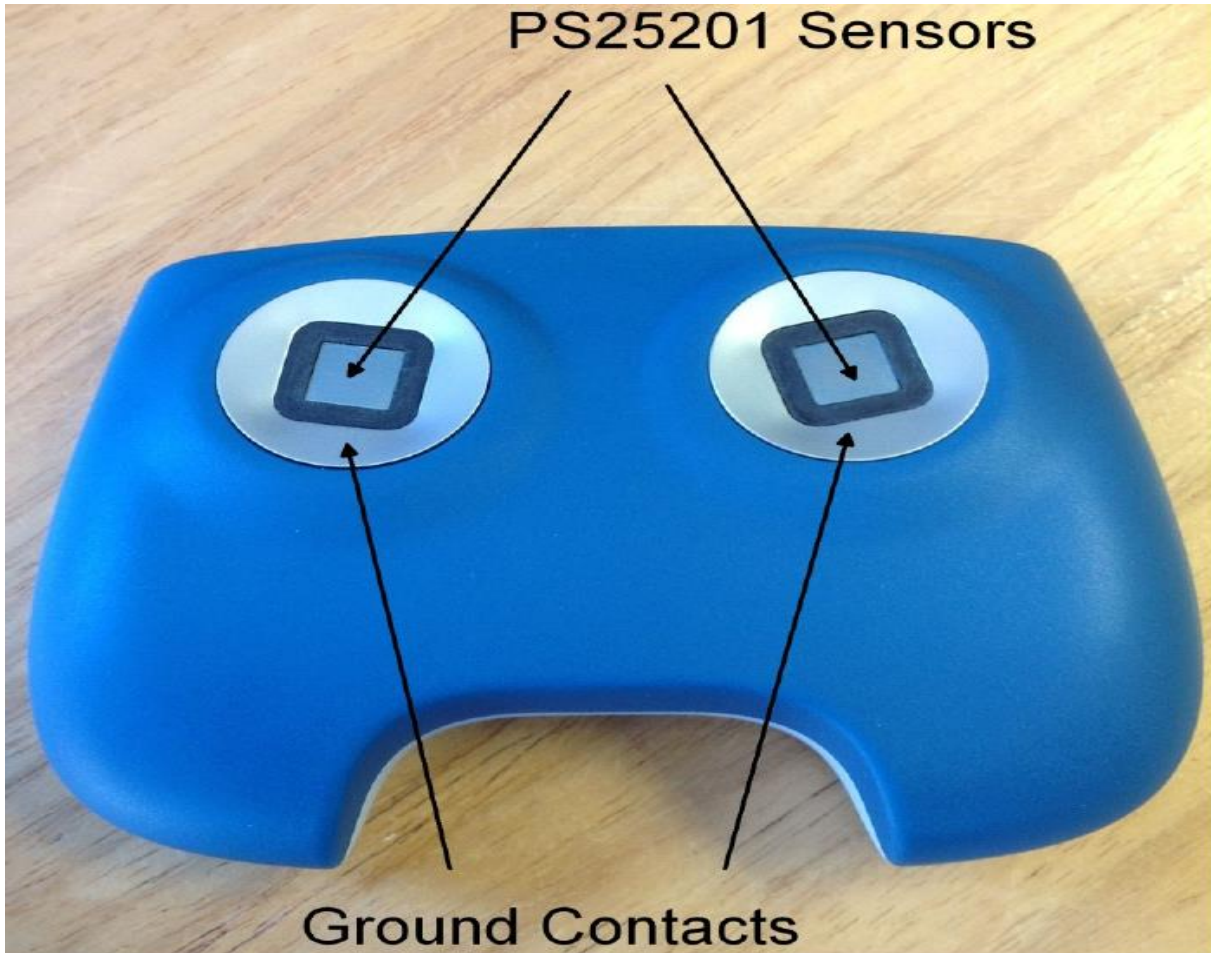

3.0 Operation

The unit should be charged for a minimum of 8 Hrs before it is first used. This can be accomplished by connecting the USB port to either a USB wall charger or to a PC. When the unit is charging the red 'Charge' L.E.D. will be lit.

After the unit has been charged it may be switched on by pushing the on/off switch. This does not latch. It is pushed once to power on the device and then again to switch it off. When the unit is powered on then the status L.E.D. will be lit.

The unit can then be paired with a mobile 'phone or tablet running the Android operating system.

4.0 Installing the software and pairing the device.

The software installation package is a simple 'apk' file which Plessey will email to interested parties or provide on other media.

The Android 'phone must first be connected to a PC via a standard USB link.

The file 'EpicTrace.apk' should then be copied to the root directory of the 'phone. Once the file has been copied the USB cable should be removed between the 'phone and PC.

On most Android 'phones the application can be installed simply by finding it using the Android file explorer. Simply locate the file and click on it to install. In some cases it may be necessary to set the android device to allow it to install apps from unknown sources, or out of market applications.

Locate the Plessey EPIC Trace logo in the applications area of the 'phone (it looks like a Plessey logo) and select it.

When the software is running then press the 'menu' button.

Selecting the 'Connect a device' tab will allow you to pair the 'phone with the *imPulse*. The pass code is '12345'.

On some versions of the Android OS it may be necessary to do this from the 'phone's 'settings' panel.

After the 'phone has been paired it may be necessary to press the 'Connect a device' tab again and connect with the *imPulse*.

A white signal trace on the blue background should then be seen advancing from left to right.

5.0 Displaying an ECG trace.

The unit should be held lightly in both hands as shown below. The thumbs should rest upon the inner sensor plates and lightly touch the grounding rings as illustrated below.

6.0 Disclaimer

Information provided in this User Guide by Plessey Semiconductors Limited ("Plessey") is believed to be correct and accurate but Plessey accepts no liability for errors that may appear in this document, howsoever occurring, or liability arising from the use or application of any information or data provided herein .

The *imPulse* is a test product and neither Plessey nor its EPIC Technology Licensor the University of Sussex ("Sussex") makes any representation or gives any warranty or undertaking in relation to it, and so far as permitted by law, all conditions, warranties, representations and other obligations on the part of Plessey and Sussex are excluded. Without prejudice to the generality of the above, no representation, warranty or undertaking is given;

(a) that the *imPulse* is of satisfactory quality or is fit for any particular purpose, has been developed with reasonable care and skill, or is safe to use;

(b) that the *imPulse* is suitable for monitoring or diagnosing any physiological function, condition or illness;

(c) that the *imPulse* has been manufactured or tested in accordance with applicable laws and regulations governing the manufacture and testing of medical devices;

The *imPulse* must not, in any circumstances be used , nor data arising from its use be used to inform any decision about the health, welfare, monitoring or treatment of any human being.

3.2.1.1.2 *imPulse* +

User Manual

Space holder

3.2.1.1.3 *imPulse ++*

User Manual

Space holder

3.2.2 Sports Watch

Purpose

This application note describes how Plessey Semiconductor's Electric Potential Integrated Circuit (EPIC) sensor can be used as a wrist-mounted device for simple and effective personal monitoring of electrocardiograph (ECG) signals.

Introduction

EPIC is an electrometer capable of sensing ECG signals through insulated sensors in contact with the skin. The sensors are dry-contact, so that the gels or other contact-enhancing substances normally associated with wet-electrode ECG pads are not necessary. As well as offering exciting possibilities for simplified ECG monitoring by medical professionals, this technology also makes it possible for individuals to view and collect their own detailed ECG signals by use of a simple device no larger than a wrist watch, or even by a device built into a wrist watch.

The ECG trace ideally requires two sensors to measure electric signals from parts of the body on opposite sides of the heart. Users familiar with the EPIC demonstration kit will know that this can easily be achieved by touching one sensor electrode with each hand. A typical differential signal is shown in figure 1.



Figure 1: Differential signal from two sensors in contact with the skin showing ECG trace

Wrist-mounted Application

A straightforward extension of the "sensor in each hand" method can be achieved by use of a wrist-mounted device containing two electrodes.

One electrode is situated on the rear of the device, and is thus in permanent contact with the wearer's wrist. The second electrode is front-facing. To provide the second signal for the ECG, the wearer simply has to touch this second sensor with a finger from the opposite hand. A representation of this configuration is shown in figure 2.

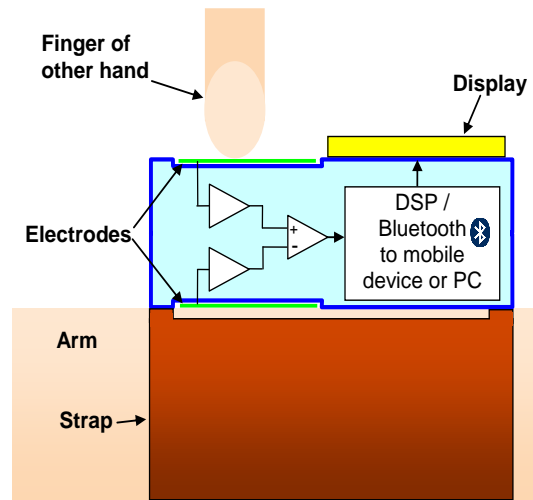

Figure 2: Diagrammatic representation of wrist-mounted EPIC configuration for taking ECG measurements

There are a number of advantages in using this configuration rather than separate sensors:

- The method is as simple as taking a pulse measurement.
- Signal collection and processing can be performed within a single unit
- Cost is reduced by use of a single housing, rather than needing one per sensor.
- There is no need for a second sensor on the end of a cable that could easily become lost or damaged.

Signal processing

The collected signals would ideally be filtered and differentially amplified by circuitry within the wrist-mounted device to produce the ECG signal. Full ECG generally requires a bandwidth of 50mHz to 150Hz; basic monitoring – for instance of heart rate – could use a much smaller bandwidth.

3.2.3 Smart phone

Purpose

This application note describes how an ECG (ElectroCardioGram) can be measured using a SmartPhone with a case containing Plessey Semiconductors' Electric Potential Integrated Circuit (EPIC) sensor.

Introduction

EPIC is an electrometer capable of sensing ECG signals through insulated sensors in contact with the skin. The sensors are dry-contact, so that the gels or other contact-enhancing substances normally associated with wet-electrode ECG pads are not necessary. As well as offering exciting possibilities for simplified ECG monitoring by medical professionals, this technology also makes it possible for individuals to view and collect their own detailed ECG signals on a portable device such as a SmartPhone.

SmartPhone Application

The ECG trace ideally requires two electrical signals from parts of the body on opposite sides of the heart. By mounting two sensor electrodes on the rear of a SmartPhone case, these signals are easily obtained from fingers on both hands just by holding the phone, as shown in figure 1.

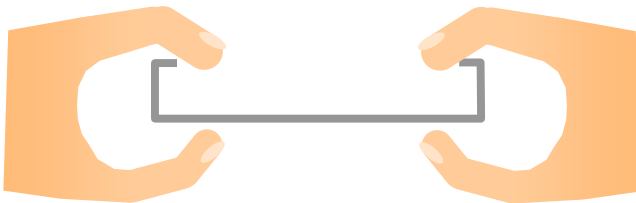

Figure 1: Diagrammatic representation showing user holding smartphone and touching one sensor with each hand

To produce the ECG trace shown in figure 2 the ECG sensor in a SmartPhone application requires

1. A case - into which is built the EPIC sensors and some electronics to amplify, filter and digitise the signal and send the signal to the phone.
2. A software app to receive, process and analyse the data and display the waveform.



Figure 2: ECG trace on a smartphone

Signal processing

The collected signals should be filtered, differentially amplified and digitised by circuitry within the SmartPhone case to produce the ECG signal. Full ECG generally requires a bandwidth of 50mHz to 150Hz.

The signal is sent to the phone by bluetooth. Further analysis of the ECG trace can be performed by software with the phone app, for instance to display heart rate or other key parameters from the PQRST waveform.

Further development of the software could enable the data to be sent to – for instance – a clinic or doctor's surgery for monitoring by healthcare professionals.

Once the signal has been digitised, numerous methods of analysing, displaying or transmitting the data are obviously possible. These could include:

- Data output to a display on the device itself, for example displaying the heart rate, or more detailed parameters from the PQRST pattern that are indicators of the health of the heart.
- Data transmission via Bluetooth to a mobile device (e.g. SmartPhone) for display of the full ECG trace.
- Incorporating the device into a cloud computing network.

The low power requirements of the EPIC sensor allow the biasing for the sensor and the filtering and amplification circuitry to be battery operated.

3.2.4 Single arm ECG measurement

Purpose

This application note describes a method for measuring ECG (ElectroCardioGram) signals from a single arm using Plessey Semiconductors' Electric Potential Integrated Circuit (EPIC) sensors. This enables continual heart monitoring without the need for chest straps or contact points on both sides of the body.

Introduction

EPIC is an electrometer capable of sensing ECG signals through insulated sensors in contact with the skin. The sensors are dry-contact, so that the gels or other contact-enhancing substances normally associated with wet-electrode ECG pads are not necessary. The signal is obtained by differentially amplifying the output of two sensors with high common mode rejection.

Applications for measuring ECG signals using EPIC thus far have required contact points from both sides of the body, i.e. either side of the heart.

For applications that require continual monitoring of heart rate – for example during exercise or longer term cardiac monitoring for those with heart problems – it is advantageous to be able to take signals from just one arm, thus avoiding cumbersome wiring across the body or the need to touch a wrist-mounted sensor with opposite hand [1].

Single Arm Application

As stated by Yang et. al. [2], cardiac signals strong enough to be differentiated from background noise exist in the upper arm.

Figure 3 shows signals from two EPIC sensors mounted on the upper left arm. The sensors are positioned such that the electrical cardiac signals are out of phase, hence giving a strong differential signal and thus good signal to noise ratio. The traces from the individual sensors and the differential are shown in figure 3. Signals have been bandpass filtered to remove unwanted noise artefacts.

Sensor positioning

There are three main considerations in terms of sensor positioning that affect the quality of the ECG signals that can be achieved from a single arm.

1. Choice of Arm

Figures 3 and 4 show traces obtained from pairs of sensors in approximately the same positions on the left (fig 3) and right (fig 4) arms of the same subject. The plots are shown side by side and on the same scale for easy comparison. Although the heartbeat is clearly detectable from the sensors on the right arm, the magnitude and quality of the signals are far superior with sensors mounted on the left arm (i.e. nearer the heart). Positioning sensors on the left arm is therefore recommended.

2. Distance from shoulder

The magnitude of the cardiac signal decreases significantly as the sensors are moved down the arm, away from the shoulder. The signals shown in figure 4 were measured with the sensors positioned 2-3cm below the armpit. The QRS region of the differential signal has an amplitude of approximately $\pm 30\text{mV}$ (x10 external gain). Moving the sensors 3cm further down the arm reduces this peak to peak signal by about half to around $\pm 15\text{mV}$. Sensors should be positioned as far up the arm towards the shoulder as possible.

3. Position around the arm

Signal quality is significantly affected by where the sensors are situated around the arm. There are two primary considerations

a) Signal strength and phase.

Signal strength varies considerably as the sensor positions are moved around the arm. As already stated, out of phase signals can be detected by appropriate positioning of the sensors, leading to the best differential signal.

b) Unwanted signal rejection

The major unwanted signals in this case are the electrical signals produced by the muscles that control arm movement (pectoral, deltoid etc.). The strength of these electromyographic (EMG) signals varies around the arm.

In some positions the EMG signal from active muscles is significantly larger than the cardiac signal, completely obscuring it. By changing the sensor location the EMG signal can be greatly reduced, allowing the cardiac signal to be seen above the background EMG "noise".

The sensor locations that give the largest amplitude cardiac signal from an arm with relaxed muscles will not necessarily give the best EMG rejection, and so the optimum sensor positioning will depend on the requirements of the application. Figures 5 and 6 show the relative strength of cardiac and EMG signals in different sensor locations as the wearer's arm is raised.

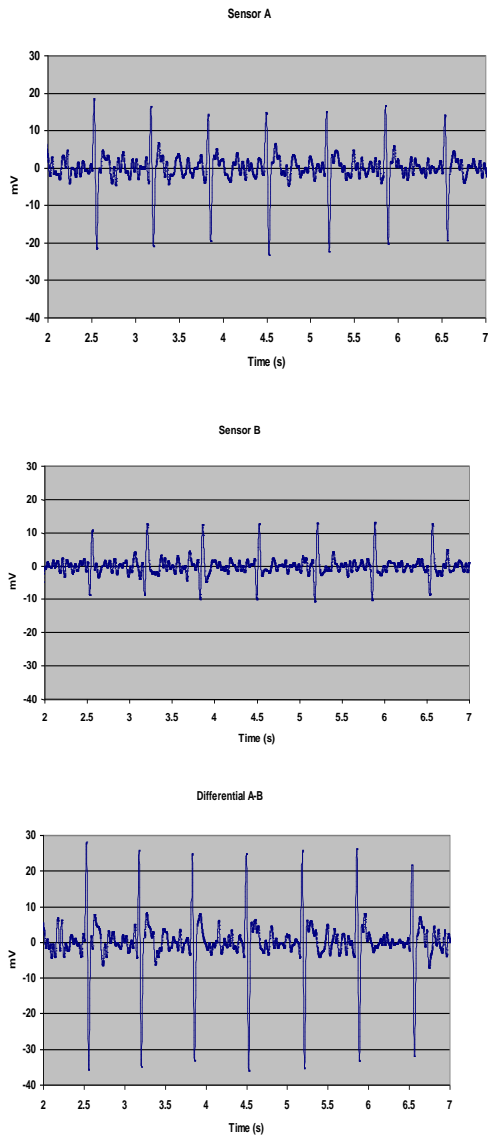

Figure 3 – ECG signals from sensors mounted in a sports armband on the left upper arm from a stationary subject. The graphs show the individual sensor outputs and the differential output, as labelled

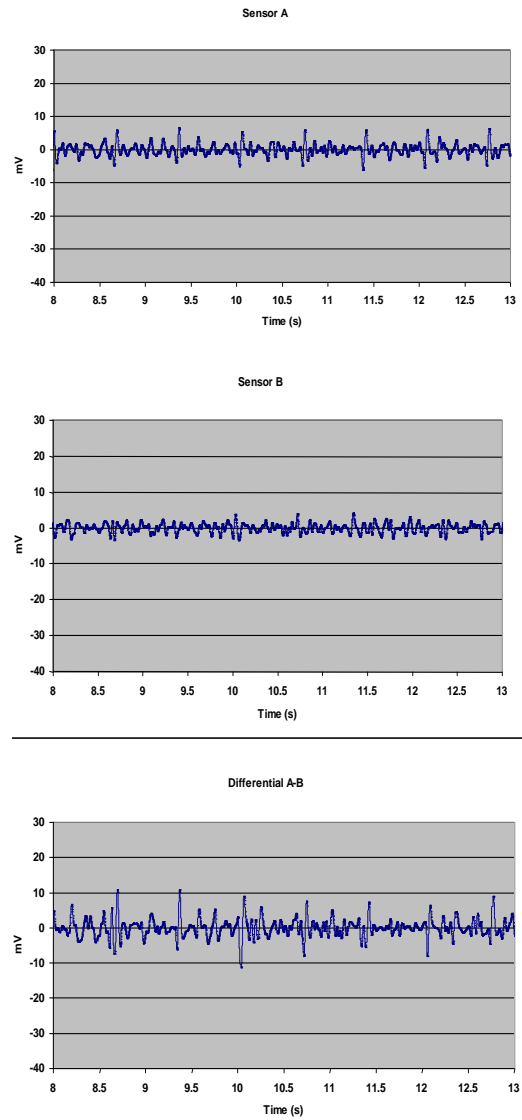

Figure 4 – ECG signals from sensors mounted in a sports armband on the right upper arm from a stationary subject. Scales are as for figure 3. The graphs show the individual sensor outputs and the differential output, as labelled.

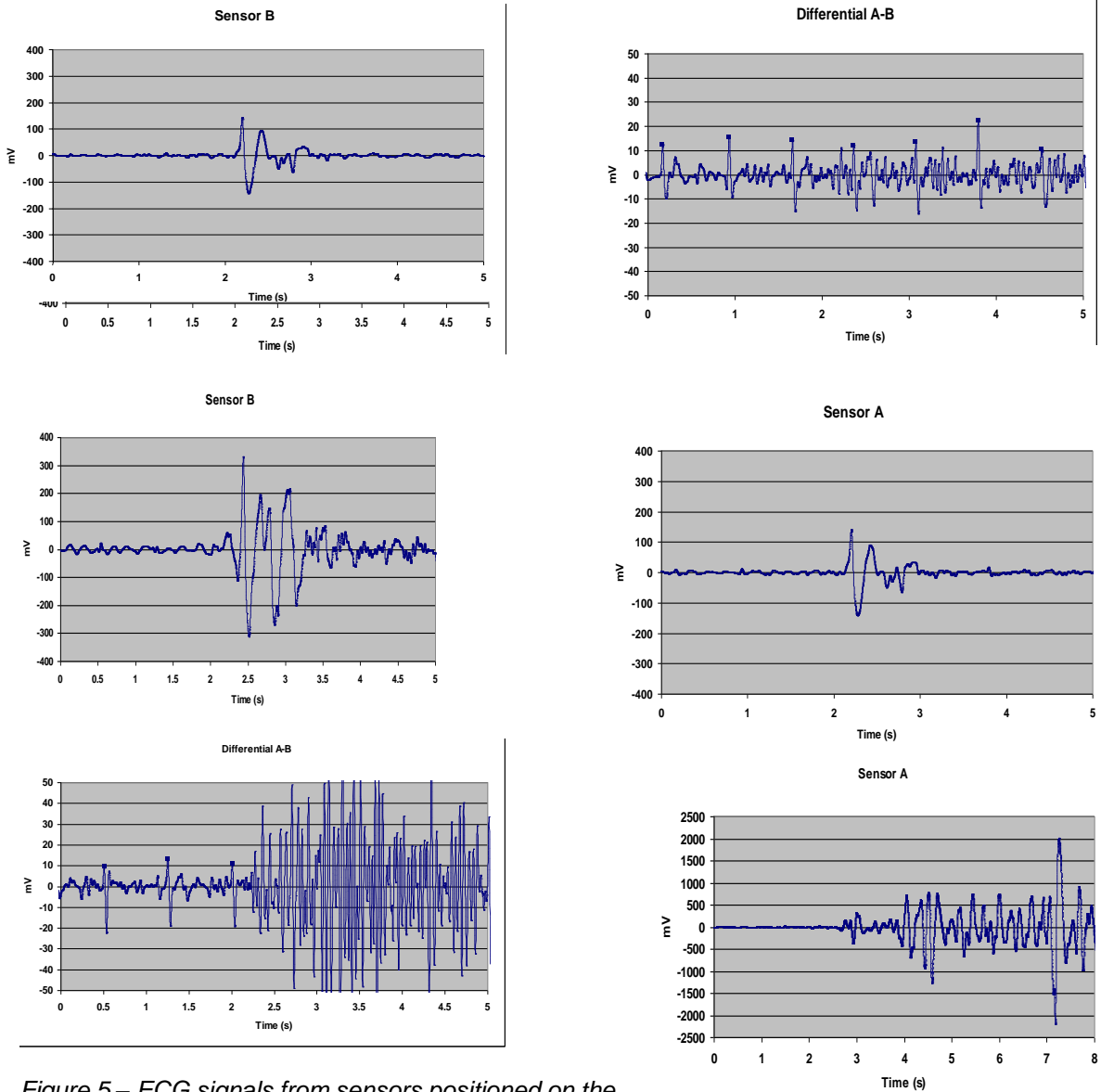

Figure 5 – ECG signals from sensors positioned on the top side of the left upper arm (as shown in fig 1b). The arm was raised after 2.1 seconds. The EMG signals completely mask the ECG signals.

Figure 6 – ECG signals from sensors positioned on the underside of the left upper arm (as shown in fig 1a). The arm was raised after 2.1 seconds. The EMG signals are much smaller than in figure 5 because of the different sensor location on the arm, such that the position of the cardiac signals can still be clearly seen.

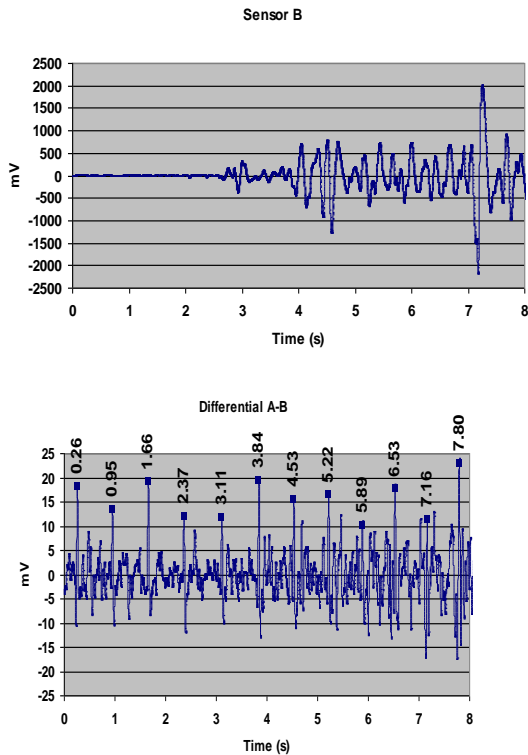

Figure 7 – ECG signals from sensors mounted in a sports armband on the left upper arm of a moving subject. The subject began walking after 2.5 seconds, as shown by the increase in signal amplitude on the individual sensors. Note that the y-axis scale is 100 times smaller for the differential trace (bottom) as the large common mode signals are rejected by the differential amplifier. The times corresponding to the QRS part of the ECG signal are shown on the differential trace.



Figure 8 – PS25101 sensors mounted on a commercially available Sports Armband mobile



Figure 9 – Sports Armband in position. Sensors are in contact with the underside of the arm, adjacent to the armpit

3.2.5 Hand rail scales

Purpose

This application note describes how Plessey Semiconductors' Electric Potential Integrated Circuit (EPIC) sensors can be included in a hand rail scale to facilitate simple and effective monitoring of electrocardiograph (ECG) signals.

Introduction

EPIC is an electrometer capable of sensing ECG signals through insulated sensors in contact with the skin. The sensors are dry-contact, so that the gels or other contact-enhancing substances normally associated with wet-electrode ECG pads are not necessary. As well as offering exciting possibilities for simplified ECG monitoring by medical professionals the device can also be easily integrated into devices such as medical 'handrail' scales or wheelchair scales.

The ECG trace ideally requires two sensors to measure electric signals from parts of the body on opposite sides of the heart. Users familiar with the EPIC demonstration kit will know that this can easily be achieved by touching one sensor electrode with each hand. A typical differential signal is shown in figure 1.



Figure 1: Differential signal from two sensors in contact with the skin showing ECG trace

Scale mounted sensors

A straightforward extension of the "sensor in each hand" method can be achieved by building (or adding) a sensor to each handrail on a medical 'handrail scale' or 'wheelchair scale'. The low power requirements of the EPIC sensor allow the biasing for the sensor and the filtering and amplification circuitry to be battery operated.

One electrode is situated in each of the rails so that the subject's palm/hands make natural contact. The frame of the scales provides an excellent common mode ground between the sensors. A representation of this configuration is shown in figure 2.

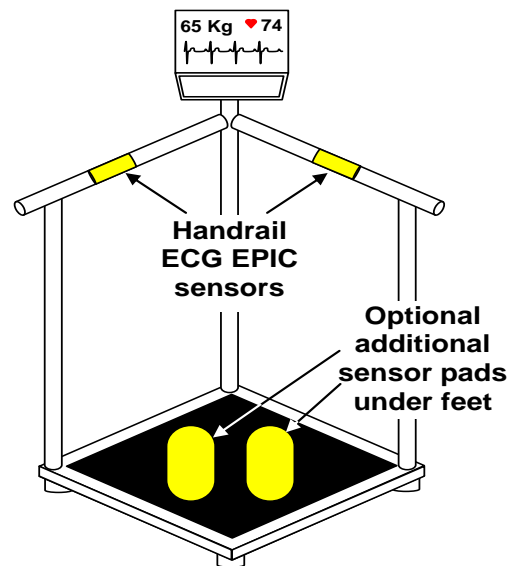

Figure 2: Diagrammatic representation of scale mounted EPIC sensors for Pulse/ECG monitoring. There are a number of advantages in using this configuration

- Left arm to right is a standard (lead 1) vector.
- Other leads can easily be added by for example incorporating foot contacts.
- The method is as simple as taking a pulse measurement and can give a 'lead 1' ECG
- Signal collection and processing can be performed within a simple single unit.
- Sensors are rigidly mounted and protected from mechanical damage and wear.

Signal processing

The collected signals are filtered and differentially amplified by simple analogue/digital circuitry within a control box or can easily be integrated into existing scale hardware/software. Full ECG generally requires a bandwidth of 50mHz to 150Hz; basic monitoring – for instance of heart rate – could use a much smaller bandwidth; both can be achieved.

3.3 Driver Health

[Plessey PS25502PAD – EPIC 6-sensor Seat Pad. Instruction Manual](#)

3.3.1 Introduction

The Plessey PS25502PAD is a seat pad containing 6 EPIC sensors and a ground plane, designed for use as part of a non-contact capacitive ECG (c-ECG) monitoring system. The sensors are located on the upright part of the seat back, with the ground plane being situated on the base.

When used along with the PS25006 multiplex box and one of the EPIC demonstration kits (PS25000, PS25001 or PS25003), the PS25502PAD forms a system for noncontact monitoring of single lead c-ECG. The system is designed to enable

Straightforward evaluation of Plessey's EPIC technology for measuring non-contact c-ECG through a variety of materials, particularly in automotive applications.

Standard Components

PS25502PAD

- 1 x PS25502PAD seat pad.
- 1 x Detachable automotive grade leather cover
- 1 x Detachable cotton cover



Figure 1 – PS25502PAD seat pad, with leather cover, in place on a car seat

3.3.2 The PS25502PAD

The PS25502PAD contains 6 x PS25203 EPIC sensors mounted on PS25012A application boards. The sensors have x10 internal voltage gain. Data sheets for both the sensors and application boards are published separately and may be found on Plessey Semiconductors' website, www.plesseysemi.com. Note that the sensors do not include the dielectric capping material that is used on standard PS25203s, since the seat cover acts as the dielectric.

The 6 sensors are positioned as shown in figure 2, enabling pairs of sensors at a variety of heights and offsets from the centre of the user's back to be selected. This provides close-to-optimum sensing positions for the majority of users, regardless of size and physique.

The pad also contains a piece of conductive fabric, concealed under the cotton cover on the seat base, which serves as the electrode for the driven ground plane. It should be connected to a *Driven Right Leg* (DRL) circuit such as the one contained within the PS25006 box, for noise cancellation.



Figure 2 – Showing locations of the 6 sensors and the DRL fabric electrode

The sensor array is concealed under a removable cover. Two types of covers are provided, one in 100% cotton material, and the other in automotive grade leather. The covers are held in place by Velcro hook and loop fasteners. The covers may – of course – be replaced by any other material of the user's choice for evaluation purposes.

The areas of electrodes 2 to 5 are increased over the standard 100mm² area of the PS25203 sensor by the addition of conductive fabric. This is to enable evaluation of the benefits of increased sensing area when using covering or clothing materials that have a lower coupling capacitance per unit area due to their thickness or dielectric properties

3.3.3 Operation

1. Position the seat pad on the chair or car seat.

Ensure that the upright part of the seat back rests correctly against the back of the chair as shown in figure 3:



Figure 3 – Correct positioning of the seat pad

The pad must not be placed as shown in figure 4, as the sensors will not be in the correct position and will not make good contact to the occupant's back:



Figure 4 – Incorrect positioning of the seat pad

2. Secure the elastic strap behind the seat.

3. Fit the appropriate cover (cotton or leather) to the seat pad. The pads are secured using Velcro hook and loop fastener strips. Ensure that the Velcro is not preventing the cover from making good contact with any of the sensor electrodes.
4. Insert the 6 numbered LEMO connectors from the PS25502PAD cable harness into the 6 numbered LEMO sockets on the front panel of the PS25006 box.
5. Insert the blue DRL plug into the socket on the rear panel of the PS25006 box.
6. Using 2xPS25013 cables (4 pin DIN to 5 pin LEMO), connect the outputs from the PS25006 box to the A and B inputs on the Control and Interface Box.
7. Connect the Control and Interface Box to the USB port of a computer, and switch on the Control and Interface Box. The red LED indicators on both boxes should light. Due to the sensitivity of the DRL circuit to power supply noise, it is recommended that the system is either run from a battery-powered laptop, or from a PC whose power supply includes a mains ground connection. Using a computer that is powered by a power supply with no external ground can lead to very noisy signals from which it is impossible to extract the c-ECG signal.
8. Sit on the pad, being careful to ensure that the positioning as described in step 1 is maintained. Lean back against the pad/chair back such that good mechanical contact is made between the occupant's back and the sensor electrodes.
9. It is recommended that after sitting down the user touches the 0V potential of the system (e.g. the metal of one of the LEMO connectors) for a few seconds to discharge any electrostatic build up. This may not be necessary under all conditions, but will often aid in getting the best signal in the shortest possible settling time.
10. Use the "Channel Select" knobs to select the pair of sensors that you wish to view. For further details, and for information on how to set the DRL gain, see the manual for the PS25006 box. Note that although the best signal will often be obtained by using two sensors at the same height (e.g. 1 & 6 or 2 & 5), in some cases a better result can be obtained by using sensors at different heights.

4.0 Electrical connectors

The LEMO connectors are wired as below (viewed looking into plug from front):

- Pin 1 Output (red dot on top of plug housing)
- Pin 2 Gnd
- Pin 3 Supply
- Pin 4 Gnd
- Pin 5 Not used (no pin)
- Case Gnd

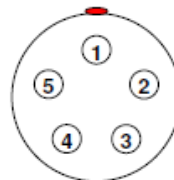

5.0 Related documents

The following documents pertaining to non-contact capacitive ECG measurements using EPIC, and the sensors used in the PS25502PAD are all available from Plessey Semiconductor's website at www.plesseysemi.com.

- a) Application Note #291566 - Non-contact ECG measurement using EPIC.
- b) Datasheet #292012 - Plessey PS25006 - EPIC 6:2 Multiplex box Instruction Manual.
- c) Datasheet #291540 - Plessey PS25000A and PS25001A EPIC Demonstration Kit
- d) Datasheet #291839 - PS25203B EPIC Ultra High Impedance Electrophysiological Sensor
- e) Datasheet #291503 - PS25012A3, PS25012B3 Application Boards for EPIC sensor PS25203

A video demonstrating the use of a capacitive ECG monitoring system using EPIC in a moving car can also be found on the Plessey website.

6.0 Disclaimer

Information provided in this User Guide by Plessey Semiconductors Limited ("Plessey") is believed to be correct and accurate but Plessey accepts no liability for errors that may appear in this document, howsoever occurring, or liability arising from the use or application of any information or data provided herein.

The PS25502PAD is a test product and neither Plessey nor its EPIC Technology Licensor the University of Sussex ("Sussex") makes any representation or gives any warranty or undertaking in relation to it, and so far as permitted by law, all conditions, warranties, representations and other obligations on the part of Plessey and Sussex are excluded. Without prejudice to the generality of the above, no representation, warranty or undertaking is given;

(a) that the PS25502PAD is of satisfactory quality or is fit for any particular purpose, has been developed with reasonable care and skill, or is safe to use;

(b) that the PS25502PAD is suitable for monitoring or diagnosing any physiological function, condition or illness;

(c) that the PS25502PAD has been manufactured or tested in accordance with applicable laws and regulations governing the manufacture and testing of medical devices; The PS25502PAD must not, in any circumstances be used, nor data arising from its use be used to inform any decision about the health, welfare, monitoring or treatment of any human being.

3.3.4 DRL

Non-contact ECG measurement using EPIC

Purpose

This application note describes a method for measuring Electrocardiogram (ECG) signals without contact to the subject's skin. This is achieved using Plessey Semiconductors' Electric Potential Integrated Circuit (EPIC) sensors along with a driven circuit, all capacitively coupled to the subject's body through clothing. A design for the driven circuit is included, along with example ECG traces.

Introduction

EPIC is a capacitive sensor and so does not rely on ohmic contact to the body for measuring bio-electrical signals. It therefore has the ability to measure ECG without direct skin contact. Signals measured on the human body always include a large amount of noise, the major component of this being 50 or 60 Hz power line noise capacitively coupled to the body from the mains electricity supply. Measurements such as ECG depend on being able to extract the small electrophysiological signals from the much larger noise signals.

When using EPIC in "contact mode" for ECG measurement, the subject touches both the capacitive electrode surface and some metal at the system ground directly with the skin. This ground reference allows filtering and differential amplification of signals from two sensors to be effective in removing the mains frequency noise, leaving a high quality ECG signal

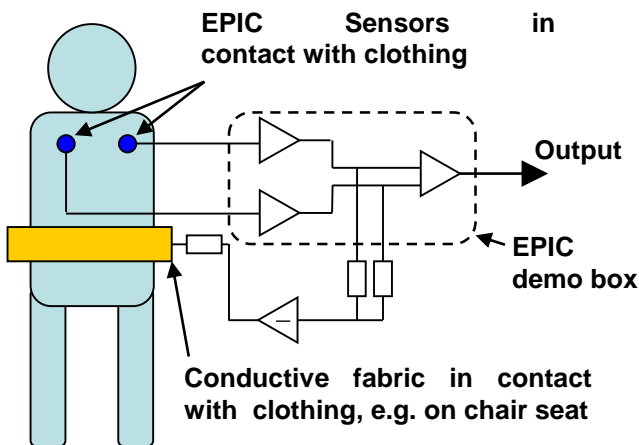

Figure 1 – Basic configuration for non-contact ECG measurement including capacitively-coupled DR" circuit.

In non-contact ECG measurement there is – by definition - no skin contact, and thus no direct connection can be made between the subject's body and the system ground. Some other method of reducing the power line noise is therefore required to enable the ECG signal to be extracted reliably and accurately. One such method utilises an approach very similar to the Driven Right Leg (DRL) system that is used for the same purpose in conventional ECG. In conventional ECG the DRL signal is coupled directly to the patient's skin; in non-contact ECG it is coupled capacitively to the body, through clothing, via a piece of conductive material placed – for instance – on the seat or back of a chair. Capacitive coupling of DRL signals is described by Lim et al¹ and Lee et al².

System design

This application note will describe a system built into a chair as a specific example, although the techniques can be readily adapted for a system built into a mattress or clothing and so forth.

The DRL circuit reduces power line noise on the sensor signals by feeding back an inverted average of the signals from two sensors onto the body, as shown in figure 1. Referring to figure 1, the EPIC sensors are mounted on the chair back such that the electrodes touch the clothing on the subject's back when resting normally against the chair back. The DRL signal is connected to a piece of conductive material placed either on the seat of the chair, or at the bottom of the chair back, such that it will contact the subject's clothing in normal sitting position.

Both copper-coated nylon fabric and aluminium foil have been used successfully for the DRL coupling material; it is expected that other conductive materials will be equally suitable. A thin, non-conductive material may be used to cover both the sensors and the DRL coupling fabric if required (for instance when building the sensors into a seat), although consideration should be given to how the choice of material will (a) reduce the coupling capacitance between the sensor and the subject, and (b) add additional noise to the signals through static charging effects. Cotton fabric is one suitable choice.

Figure 2 shows the design of the DRL circuit. It is a standard summing amplifier, generating an amplified and inverted signal that is the average of the individual signals A and B.

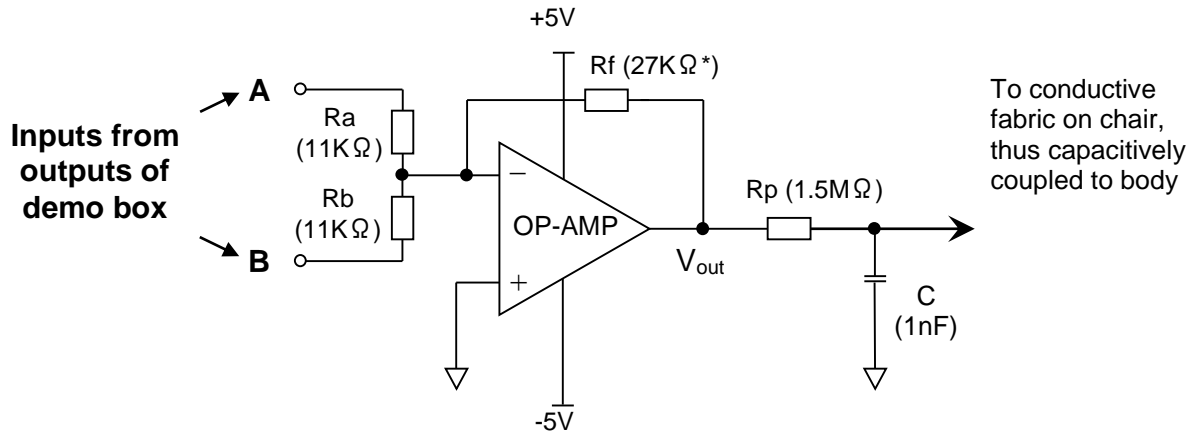

Figure 2 – DRL circuit. Voltage gain is set by R_f ; R_p limits current fed back to the body (see text).

The output (V_{out}) of the operational amplifier is given by:

$$V_{out} = - (V_A + V_B) * \frac{R_f}{11K}$$

The optimum value for R_f will be dependant on the type of sensors being used, as well as the clothing being worn by the subject being measured. It should be set to achieve maximum noise reduction, whilst ensuring circuit stability. A value of $27K\Omega$ is suggested as a suitable starting point for all EPIC sensors.

R_p , the protection resistor, is included to limit the current that can be fed back to the human body. This resistor is essential in ensuring that the subject's well-being is not endangered and must not be omitted.

Please read the section headed "Safety Considerations", before using this circuit.

Implementation

The demonstration of non-contact ECG is best performed using an EPIC demonstration kit, Plessey part no. PS25000 (50Hz notch filter) or PS25001 (60Hz notch filter). The inputs to the DRL circuit can be taken from the BNC outputs "A & B" on the front of the demo box. The DRL circuit will require its own bipolar power supply: $\pm 5V$ or $\pm 6V$ is suggested. A circuit design including a battery power supply is shown in figure 3.

Compact sensors (Plessey part numbers PS2520x) and disc sensors (PS25101) provide equally good results, although for demonstration purposes, disc sensors are easier to fix to a chair to make contact with the occupant's back than compact sensors mounted on the PS25014A application board. If using PS25014A boards, they should be mounted horizontally, with the connector housing just to the

side of the subject's back such that the subject will make contact with the electrodes (through clothing) when sitting normally in the chair. Compact sensors are recommended if designing a custom-built system.

EPIC sensors designed for contact electrophysiology sensing (part nos. as above) have given excellent results in most cases. Initial trials suggest that modifications to the sensor design (e.g. lower gain and higher input impedance) can offer increased sensitivity and thus the ability to detect weaker ECG signals. Please contact Plessey Semiconductors for advice on the latest sensor design for this application.

The shape of the ECG trace that is measured – in terms of relative magnitudes of the P, Q, R, S and T waves – will depend on the positioning of the sensors behind the subject's back. If the desire is only to measure the "R-R" interval to determine heart rate, then the siting of the sensors is not critical. Placing one sensor either side of the spine, separated by 6-10 inches (15-25 cm), at approximately the same height as the heart is recommended as a starting point. For applications where signals from other parts of the cardiac cycle are required the user should refer to texts on bioelectronic signals for guidance on sensor position.

The following hardware and software settings are recommended as starting values for system evaluation or demonstration. These may need to be adjusted, as the strength of ECG signals will always be dependant on the physiology and clothing of the person being measured.

Demo box settings

- Low Pass filter: IN
- Gain : x10 for sensors with x10 gain
x1 for sensors with x50 gain
- Notch filter: IN

Software settings

- Voltage scale: 10mV or 50mV
- Time base: 0.5s/div
- HP filter: Selected, 8Hz **
- Comb filter: Selected, N=6, Q=25
- LP filter: Selected, 25Hz **

** High and low pass filter frequencies of 8 and 25Hz will remove much of the disturbance to the signal caused by breathing etc. and can be ideal for showing the “R-R” interval of the cardiac cycle. Wider filter settings, for instance up to the HP=50mHz and LP=150Hz values required by medical ECG, can be used. Figures 4 and 5 show traces using two different filter settings. Note that the “R-R” interval is unaffected by the filter settings, but the overall shape of the measured trace can be changed significantly.

Hints

The following pointers may be useful when using the techniques described in this application note for measuring non-contact ECG signals.

Settling time – When a subject first sits in the chair and leans against the EPIC sensors, the changes in electric potential will normally send both the sensors and the DRL circuit into saturation. Because the system contains some large impedances, and hence has some very long RC time constants, settling times of tens of seconds can be needed before a clean ECG signal is seen. During this period the signal can either appear very noisy, or be virtually flat, depending on whether one or both sensors, or the DRL circuit, are “railing”. The subject should sit still during this time and wait for the circuit to settle, since continually adjusting position will

1. only make matters worse. Settling times can sometimes be reduced by turning off the power to the demo box for a few seconds.
2. Clothing – Best results have been obtained when the material between the sensors and the skin is one or two layers of cotton material. This is therefore recommended as a starting point for system evaluation. Signals have also been measured successfully through other materials, including a wool-mix sweater and a polyester fleece in addition to two layers of cotton material. Examples are shown in figures 6 and 7. If the key parameter of interest is the “R-R” interval, adjustment of filter settings to reduce or re-centre the signal bandwidth can give significant improvement in signal quality.
3. Static – Because there is no direct physical contact between the subject and any grounding point, there is no path for any static build up to be discharged. Under most circumstances static build up does not present a problem, but depending on factors including clothing, footwear, flooring, humidity levels in the air and so forth, static build up can sometimes prevent the cardiac signal from being seen clearly. In this situation the subject should briefly touch something metal connected either to an external ground or to the system ground to discharge the static.
4. Cable shielding – The EPIC demo box grounds the shielding of the sensor cable via the connection between the outer casing of the sensor plugs and the metal surround of the socket on the box. Ensuring that this connection is well made will reduce unwanted noise artefacts from the signal.

Conclusion

This application note has described how EPIC sensors can be used to measure ECG signals without physical skin contact. Although reference has been made to sensors embedded in a chair or seat, the techniques are equally applicable to sensors mounted on a mattress, in clothing or in other situations.

There are many variables that will affect signal quality, from the strength of cardiac signal generated by the individual being measured, to clothing, to the surrounding environment. The user is therefore encouraged to use the designs given here as a starting point in establishing an optimum system for a particular application.

Safety considerations

The currents required to interfere with the electrical activity of the human heart are – to the layman – surprisingly low. For instance, the American Heart Association published a discussion document in 1996³ recommending that “ECG risk currents be limited to 10 μ A through patient-connected leads.” Maximum safe current limits for any devices that are to be connected to the human body are specified in national and international standards. The widely accepted international standard is IEC 60601; some national variations exist.

Before using the DRL circuit, the user must ensure that any circuit that is to be coupled to the human body complies with the latest Medical Equipment Safety regulations, under both normal and potential fault conditions, in the country in which it is being used .

References:

- [1] YG Lim, GS Chung, KS Park. “Capacitive Driven-right-leg Grounding in Indirect-contact ECG Measurement,” *32nd Annual International Conference of the IEEE EMBS Buenos Aires, Argentina, August 31 - September 4, 2010* pp 1250-1253
- [2] KM Lee, SM Lee, KS Sim, KK Kim, KS Park “Noise Reduction for Non-Contact Electrocardiogram Measurement in Daily Life,” *Computers in Cardiology 2009*;36: pp 493-496
- [3] MM Laks, R Arzbaecher, JJ Bailey, DB Geselowitz, AS Berson. “Recommendations for Safe Current Limits for Electrocardiographs” *A Statement for Healthcare Professionals From the Committee on Electrocardiography, American Heart Association, 1996*

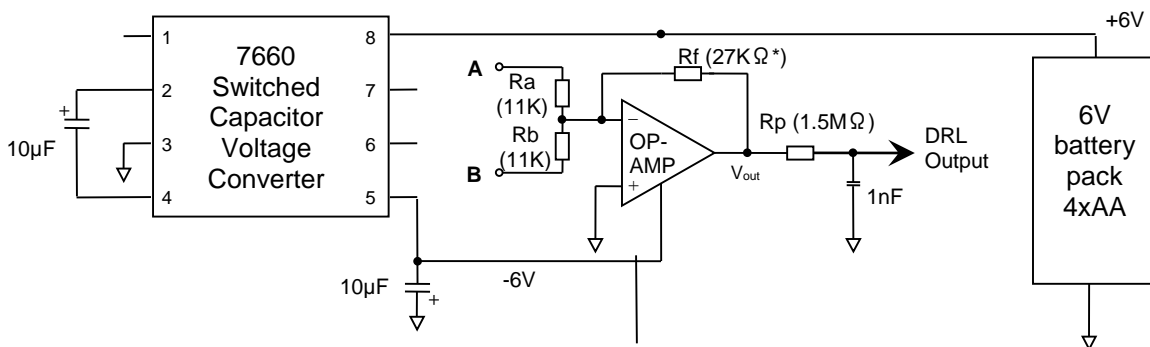

Figure 3 – DRL circuit including battery power supply and voltage converter to provide -6V rail. Inputs A and B are buffered outputs from the sensors and may be taken from the A and B outputs of the EPIC demo box. Ground should be connected to the sensor 0V, the shielding of the BNC A & B outputs on the demo box being a suitable connection point. See figure 2 and the text for further comments on the DRL design.

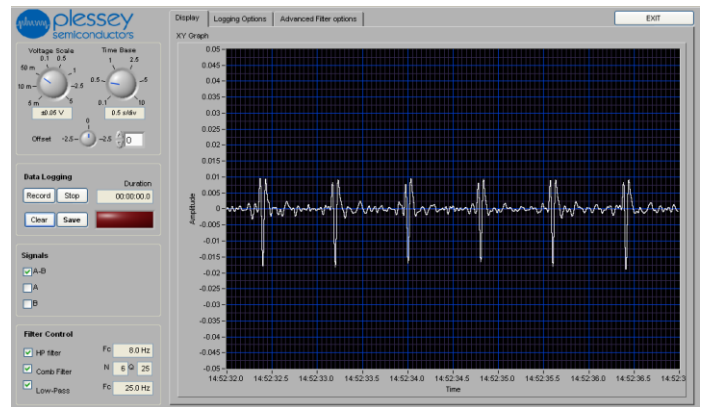
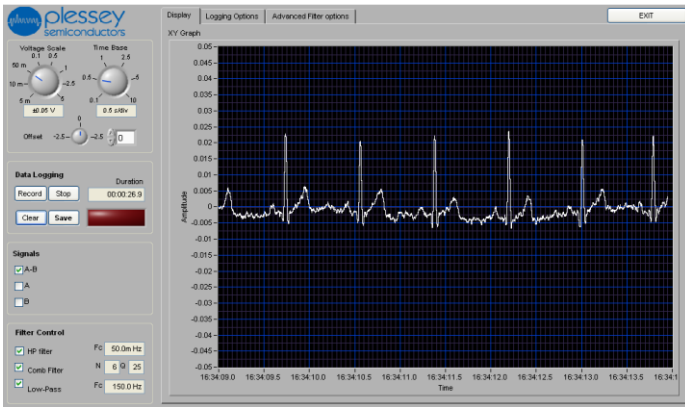

Figure 4 – Non-contact ECG signals measured through a single layer of cotton clothing, with a capacitively coupled DRL circuit. HP filter corner frequency is 50mHz, LP filter

Figure 5 – Non-contact ECG signals measured through a single layer of cotton clothing, with a capacitively coupled DRL circuit. Software filters limit the bandwidth to 8-25Hz.

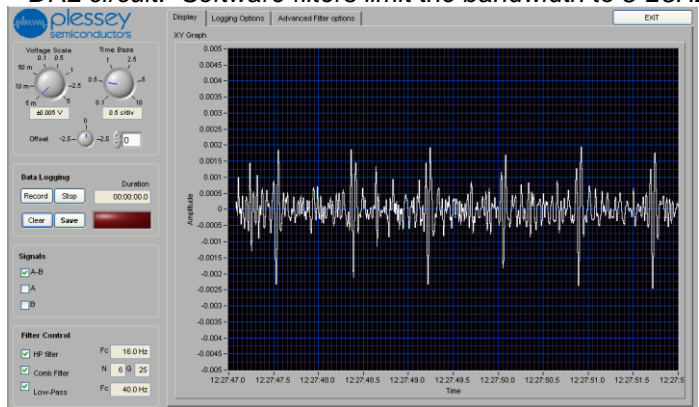
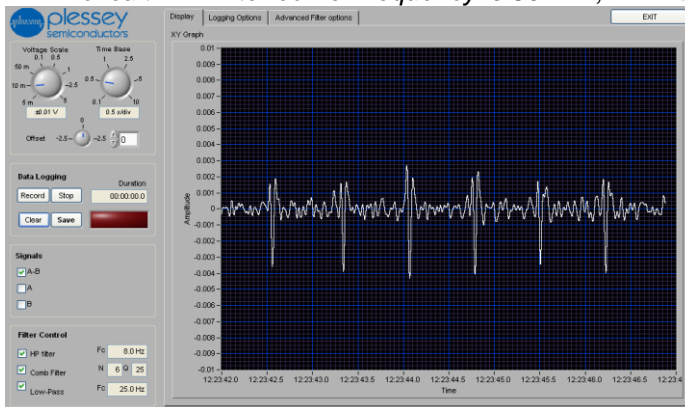

Figure 6 – ECG signals measured from a subject wearing a wool-mix sweater over a cotton shirt. Sensors attached to the chair-back were covered with an additional layer of cotton material. Filter settings limit the bandwidth to 8-25Hz. The heart rate can be easily extracted.

Figure 7 – ECG signals measured from a subject wearing a polyester fleece over a cotton shirt. Sensors attached to the chair-back were covered with an additional layer of cotton material. Filter settings limit the bandwidth to 16-40Hz. The heart rate can be easily extracted.

3.4 Identification ECG Signature/Security

Application Note

Movement and gesture applications of EPIC sensors

Purpose

This application note describes potential application of Plessey Semiconductor's Electric Potential Integrated Circuit (EPIC) sensor to movement detection, position sensing and gesture recognition of the human body.

Introduction

EPIC is a very high impedance sensor which can measure small changes in the ambient Electric field (E-field). This allows it to detect changes in local E-field due to the movement of dielectric objects such as a human body.

When a person moves, he disturbs the electric field around himself. The EPIC sensors can be configured to detect this change in the E-field and produce a proportional signal which can be used to estimate various information related to position, motion and possibly gesture. The advantage of EPIC sensor technology lies in its ability to operate completely passively. Objects can be detected moving against the Earth's static field or as stationary targets within an existent AC field.

It is sometimes also possible to operate them in covert mode, behind say a non-conductive wall.

Position, movement and gesture applications

The sensor data can be used to calculate a multitude of information including position, movement, velocity and possibly even gestures.

Since the sensor can respond to the changes in the ambient E-field, a number of configurations are possible. The sensors can be positioned in different spatial arrangements to realise various spatial measurements

A simple setup, as shown in figure 1, can be achieved by using just a pair of sensors in a differential mode. Each of the sensors can measure the existing mains frequency (50 Hz/ 60 Hz). When a dielectric object such as a finger, is placed between the two sensors, the level of the mains signal detected by the sensor is changed and this

can be displayed as a relative position within the range of the pair of the sensors.

Sensors may be placed at the corners of a room to triangulate the position of the person moving in the room with some signal processing. Figure 2 shows a possible arrangement for this.

While simple position and movement tracking using relatively small number of sensors and simple signal processing are currently possible, potential future development may lead to the following:

- It may be possible to set up multiple sensors in various spatial arrangements in two and three dimensions to measure and visualise the position and gesture of the body within the confines of the sensor boundaries. By increasing the number of sensors in arrays, the resolution of the detection can be increased opening up the possibility of determining complex gestures.
- It is possible to desensitize the quasi DC response of the EPIC sensor which may make it possible to conduct measurements in the presence of large static objects such as non-conducting walls. This enables the use of the sensor for security applications involving hidden movement detection.

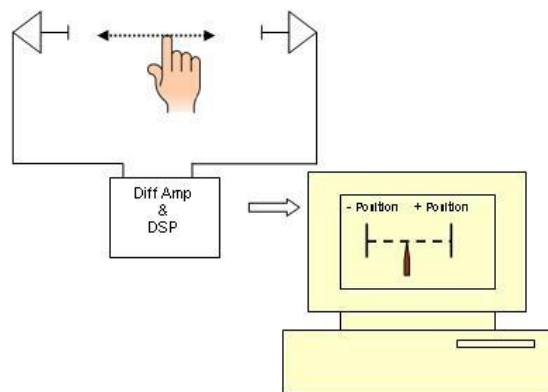

Figure 1- Finger tracking in 1-dimension, using a pair of sensor being displayed on a computer as a relative position

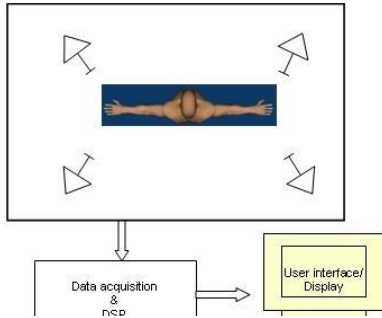

Figure 2 - Movement detection of an ambulatory human subject by four sensors at the corner of a room.

The exact position and gesture related information is extracted via some suitable algorithmic processing, based on sensor data after appropriate signal processing. The complexity of signal processing required depends on the target to be resolved in terms of the spatial precision required and the complexity of the movement and gesture.

Sensor data processing

The signal from the sensors can be easily digitized by using suitable A-to-D with reasonable resolution and sampling rate. The bandwidth of sensor necessary for this type of application can typically be <1 Hz to >200 Hz which can be easily digitized by a 1K Sample/s digitizer.

Digitizers with programmable gain amplifiers in the analogue channels are available which can be useful in restoring the signal to noise ratio from different sources. Obviously, additional gain and filtering can be incorporated prior to feeding the analogue signals through digitizers. Microprocessors with onboard A-to-D can be employed to do this and also perform the necessary algorithms to calculating the position, and movement. A visual interface can be incorporated to display the results.

3.5 Remote Sensing

3.5.1 *imPart*

3.5.1.1.1 Application Notes

4 Appendix A

- Sensor Options
- Datasheets

4.1 Sensor Options

| Supplied Sensor | Supplied Quantity | Channels | Body Style | Mounted sensor | Sensor Type | Freq. Range (-3dB) | | Voltage Gain | Termination | Supplementary Component |
|-----------------|-------------------|----------|------------|----------------|-----------------------|--------------------|-------|--------------|-------------|-----------------------------|
| | | | | | | Lower | Upper | | | |
| PS25101 | 2 | Single | Metal | N/A | Contact / non-contact | 200mHz | 10kHz | 50 | Cable + DIN | |
| PS25102 | 2 | Single | Metal | N/A | Contact / non-contact | 200mHz | 20kHz | 10 | Cable +DIN | |
| PS25012A1 | 2 | Single | Demo board | PS25201B | Contact / non-contact | 200mHz | 10kHz | 50 | Socket | PS25013 cables (supplied) |
| PS25012B1 | 1 | Dual | Demo board | PS25201B | Contact / non-contact | 200mHz | 10kHz | 50 | Socket | 2x PS25013 cables(supplied) |
| PS25012A3 | 2 | Single | Demo board | PS25203B | Contact / non-contact | 200mHz | 20kHz | 10 | Socket | PS25013 cables (supplied) |
| PS25012B3 | 1 | Dual | Demo board | PS25203B | Contact / non-contact | 200mHz | 20kHz | 10 | Socket | 2x PS25013 cables(supplied) |
| PS25014A1 | 2 | Single | Demo board | PS25401B | Non-contact | 200mHz | 20kHz | 50 | Socket | PS25013 cables (supplied) |
| PS25014B1 | 1 | Dual | Demo board | PS25401B | Non-contact | 200mHz | 20kHz | 50 | Socket | 2x PS25013 cables(supplied) |

3. The Control and Interface Box (CIB)



Control and Interface box

The Control and Interface box (CIB) provides an easy interface for the evaluation of EPIC sensors with both analog outputs and also digitised output (USB) using the internal data acquisition (DAQ) card. The front and back panels are detailed below:

FRONT

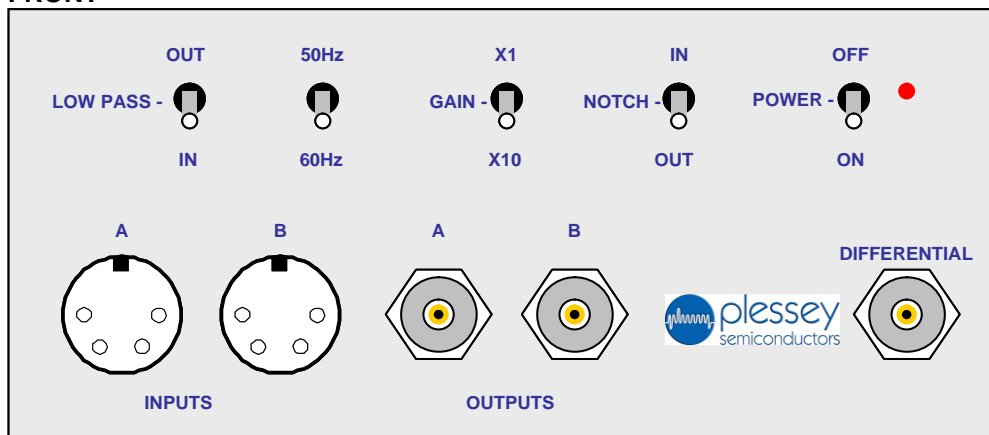

Control and Interface box front panel

- Power and signal socket for two sensors (channel A and B).
- Switchable gain of x1 and x10.
- Switchable low pass filtering
- Switchable notch filtering, used in conjunction with,
 - Notch filter frequency selector, 50 or 60Hz
- Analogue outputs for each sensor (channel A and B)
- Analogue difference output for the two sensors (channel A - channel B)

REAR

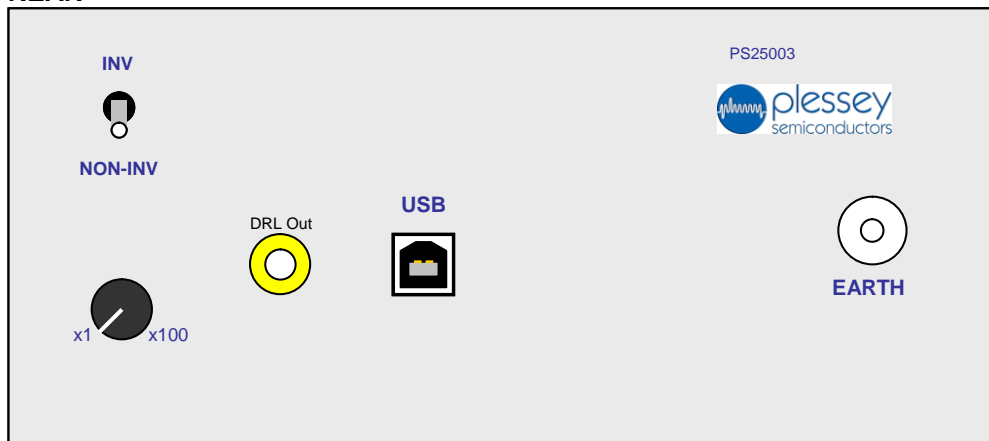

Control and Interface box rear panel

- Earth terminal
- Driven Right Leg (DRL) circuit
 - Phase selector
 - Gain control, x1 to x100
 - 4mm output socket
- A USB 2.0 interface

A short specification of the control and interface box is:

| Parameter | min | typ | max | Units | Notes |
|---------------------------|---------------|-------|-----|----------|-------|
| Supply voltage – USB 2.0 | | 5.0 | | V | |
| Low pass filter | | 30 | | Hz | |
| Notch filter | frequency | 50/60 | | Hz | |
| | attenuation | 30 | | dB | |
| | Q | 4 | | | |
| Analogue output impedance | | 10 | | Ω | |
| Data acq'n | resolution | 12 | | bit | |
| | Sampling rate | | 10 | kS/s | |
| | Output rate | | 150 | Hz | |

The power for the internal electronics of the box is provided by the data acquisition card. This is a National Instruments card, USB-6008. The internal electronics can only be powered by connection of the USB port to a computer with the driver for the DAQ installed.

4. The Control and Interface Box (CIB) Software

The CIB requires a connection to a laptop with the associated CIB software installed. The protocols provided by the software enable the internal data acquisition card within the CIB and this, in turn, provides power to the other electronics within the box.

The enabled USB connection is also required if the analogue output signals from the box are to be sent to an oscilloscope since the acquisition card is the only method of applying power to the CIB electronics.

The CIB software provides a rolling oscillogram and a chart recorder capability.

4.1 System Requirements

The system requirements for a Windows/PC system are:

| | |
|-------------------|--|
| Processor | Pentium III/Celeron 866 MHz or equivalent |
| RAM | 256 MB |
| Screen Resolution | 1024 x 768 pixels |
| Operating System | Windows 7/Vista/XP/Windows Server 2003 R2 (32-bit)/Windows Server 2008 R2 (64-bit) |

4.2 Software Installation

The software can be downloaded from the customer portal found on the internet at:

<http://www.plesseysemiconductors.com/>

Download and install the software before connection of the CIB to the computer.

Follow the on-screen installation instructions.

After installation has been performed a reboot of the system is required to complete the installation process.

4.3 Software Use

Once the software is installed the CIB may be connected to a USB socket. The CIB will be automatically detected and the driver loaded.

The software may now be started. Provided the CIB is connected and the drivers loaded then the software will display the box:

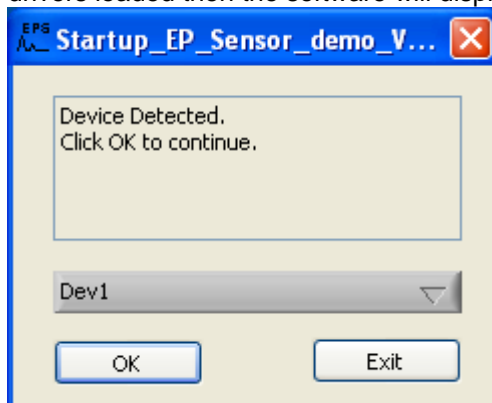

Time Base

This may be adjusted to increase or decrease the time (x) axis of the oscillogram:

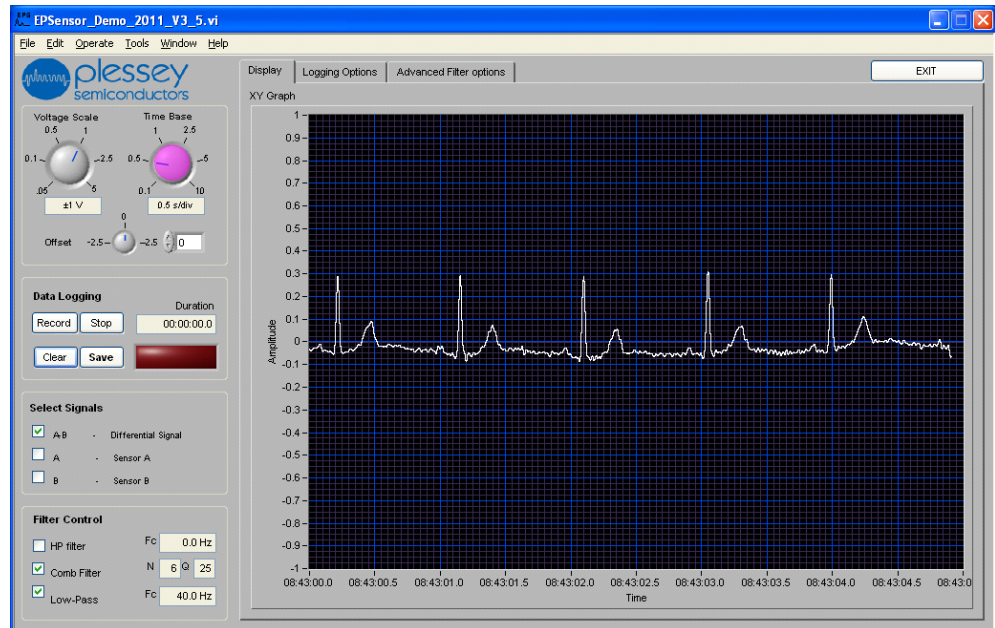

Voltage Scale

This may be adjusted to increase or decrease the voltage (y) axis of the oscillogram:

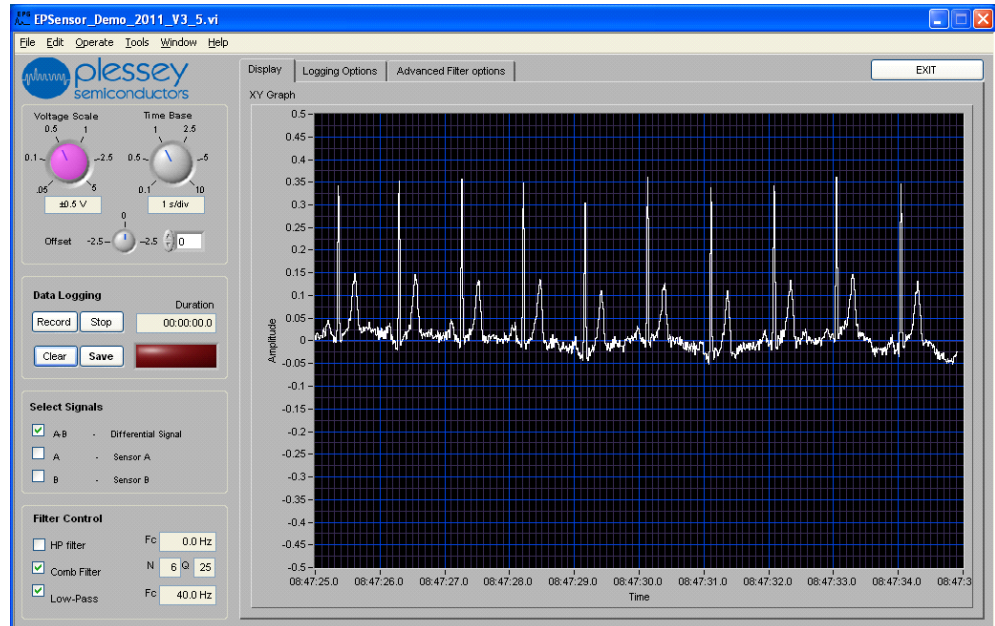

Offset

This may be adjusted to apply an offset to the voltage (y) axis of the oscilloscope:

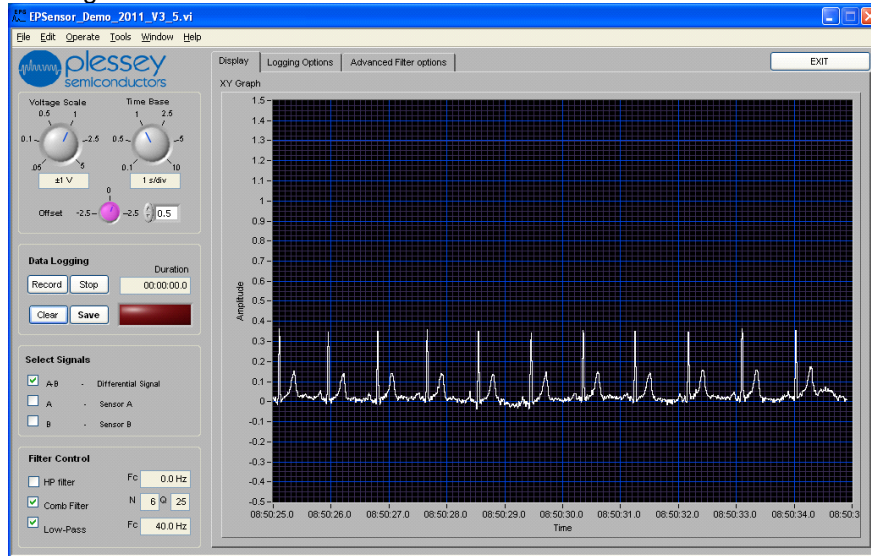

Select Signals

The Select Signals check boxes allow the displayed signals to be selected. The signal options are:

- A-B This is a difference signal between the two sensors, A and B.
- A This is sensor A signal.
- B This is sensor B signal.

None, one, two or all may be selected.

Filter Control

The Filter Control check boxes allow the following digital filters to be applied and modified:

- High Pass (HP) filter
- Comb filter
- Low Pass filter

The effect of these filters may be further modified or adjusted using the Advanced Filter options tab at the top of the screen:

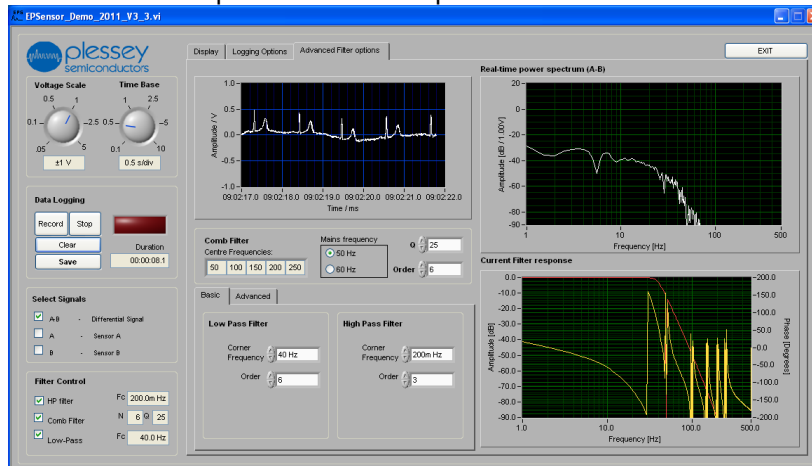

These filters are applied to the digitised signal by the local processing of the signals in the PC. These controls do not adjust or override the internal filtering options of the CIB.

Data Logging

The data logging controls on the soft front panel of the oscilloscope allow the start, stop, save and clear functions of the data recorder. Further, the Logging Options tab at the top of the screen provides additional control over the data logging function.

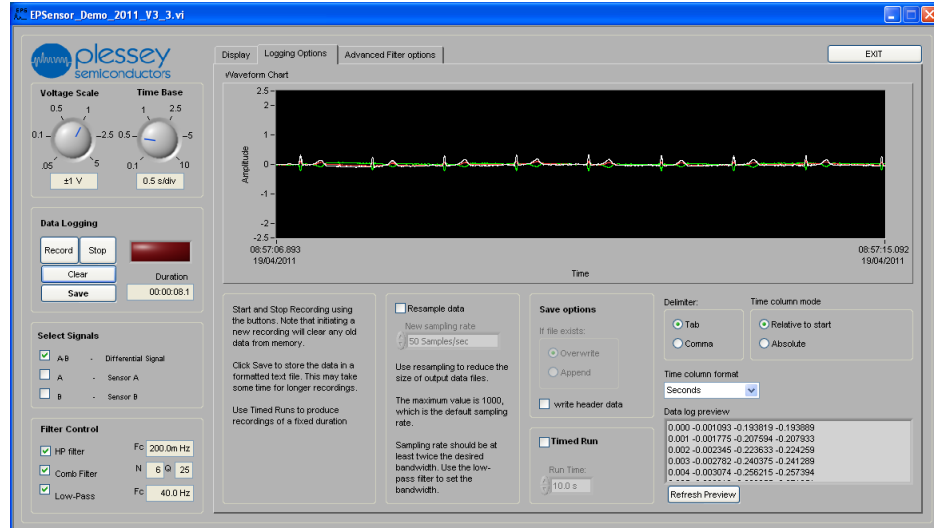

The data can be saved as a text file that is either comma or tab delimited. The data is tabulated in the form:

| | | | |
|-------|----------|-----------|-----------|
| 0.000 | 0.008346 | -0.008809 | -0.018999 |
| 0.001 | 0.009432 | -0.008183 | -0.019048 |
| 0.002 | 0.010199 | -0.007738 | -0.018926 |
| 0.003 | 0.010598 | -0.007477 | -0.018621 |
| 0.004 | 0.010596 | -0.007394 | -0.018130 |

The columns represent for following:

Time (s) A-B (V) A (V) B(V)

The data may be opened with a text editor and may be readily processed in a spread sheet. Below are example graphs made in a spread sheet.

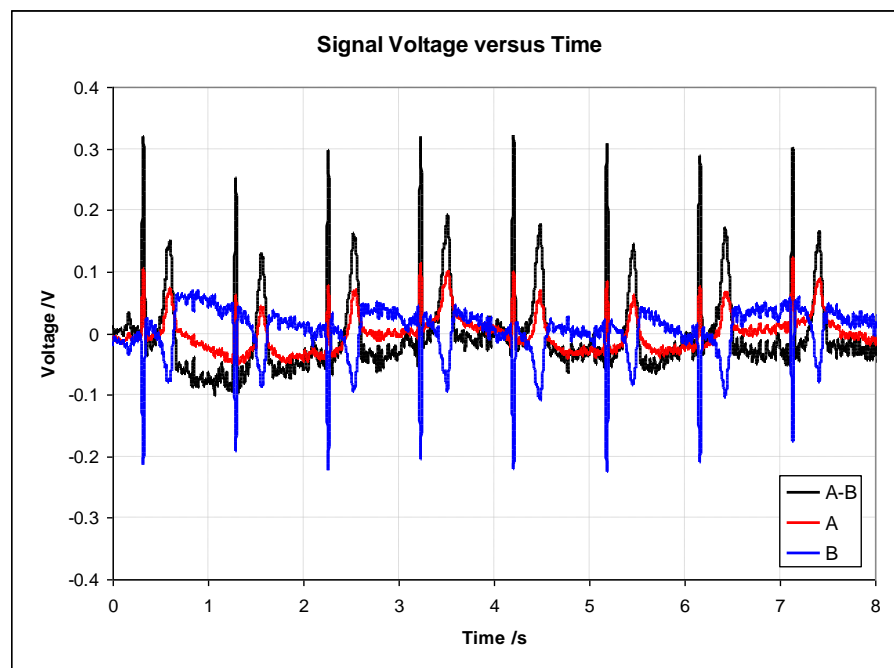

4.4 Software Shutdown

The CIB software is closed by use of the EXIT button. Once the software is closed the CIB may be switched off and then the USB connection may be broken.

It is inadvisable to disconnect the USB connection while the CIB software is running.

5. Example Applications

5.1 Obtaining an electrocardiogram (ECG) signal:

Start by setting:

- Gain to "x10"
- Low pass "IN"
- Notch filter "IN"

Oscilloscope:

If using an oscilloscope connect the control and interface box differential output to an oscilloscope using a standard BNC cable, set the time base to 0.5secs/cm and Y gain to 0.5Volts/cm dc coupled.

Virtual instrument:

If using the soft virtual instrument then drag the voltage setting to about 1.5, select "Differential A-B" from the channel selection and click on the "Start" button, the time axis should start to scroll.

Switch on the module power and hold one sensor in each hand (hands should be clean and dry) with the tips of the thumbs resting lightly (do not squeeze) on the contact surface of the sensor. It is important that both the violet coloured electrode face and outer metal case of the sensor contact the skin. After a few seconds settling time your ECG should be displayed by the oscilloscope/PC centred on 0 volts. Everyone's ECG is different so you may need to adjust the

scope setting/voltage scale for an optimal display; if the ECG appears inverted swap the sensors over to opposite hands. If you now squeeze the sensor between your thumb and forefinger you should still see your ECG but the level of baseline noise will increase noticeably; this is an electromyogram (EMG) signal caused by nerve impulses to the muscles in the forearm. The EMG signal can also be seen more clearly by placing both sensors next to each other on one forearm and then clenching the fist; no ECG signal should be present and the EMG signal level should increase the harder you clench your fist.

It is also possible to detect the ECG signal through clothing if the subject is wearing a shirt that is predominantly made of a natural fibre such as cotton. An ECG can be obtained by holding one sensor over the mid sternum and the other on the left hand side of the chest. The shape of the signal may be different to the finger tip ECG and will change depending on the relative positions of the sensors.

It is possible but not recommended to connect the sensors directly to your own equipment.

5.2 Obtaining other physiological signals:

Start by setting:

- Gain to "x10"
- Low pass "IN"
- Notch filter "IN"

Oscilloscope:

If using an oscilloscope connect the module's differential output to an oscilloscope using a standard BNC cable, set the timebase to 0.5secs/cm and Y gain to 0.5Volts/cm dc coupled.

Virtual instrument:

If using the soft virtual instrument then drag the voltage setting to about 1.5 select "Differential A-B" from the channel selection and click on the "Start" button, the time axis should start to scroll.

Switch on the module power:

An electrooculogram (EOG) signal can be seen by placing a sensor on each temple, look straight ahead and wait for the output to stabilise then by looking left then right you should see a step response as the eyeball moves. Placing the sensors above and below one eye should enable you to see up and down movement of the eye and also blinking.

It is also possible to detect electroencephalogram (EEG) signals from the head. As these signals are very small, additional amplification and filtering may be needed. By using spectrum analysis in conjunction with the EPS system it has been possible to detect alpha waves within the EEG signal.

It is possible but not recommended to connect the sensors directly to your own equipment.

5.3 Non-Contact ECG on a chair (extract from Plessey Application Note # 291566)

Start by setting:

- Gain to "x1" (for PS25101 or PS25201/401 sensors) or
- Gain to "x10" (for PS25102 or PS25203 sensors)
- Low pass "IN"
- Notch filter "IN"
- Phase switch "INV" (for all the above sensors)

Connect the DRL output signal to the conductive fabric on the seat of the chair using the flying lead provided.

Place the two sensors on the seat back approximately to the left and right of the spine and mid back.

Virtual instrument:

If using the soft virtual instrument then:

- Select "Differential A-B" from the channel selection.
- Set filters
 - High Pass "IN" 8.0 Hz
 - Comb "IN" 6 – 25 Hz
 - Low Pass "IN" 40.0 Hz
- Voltage scale: 10mV or 50mV
- Time base: 0.5s/div

Start the oscillogram. Adjust the gain of the DRL circuit using the gain control on the back plane of the Control/Interface box. If the gain is too low the ECG signal is lost in the common mode signal and no net signal can be retrieved. If the gain is too high the system becomes unstable. There will be an optimum gain when the differential ECG signal is produced. The soft oscilloscope gain may need to be increased to observe the signal. The position of the sensors may need to be adjusted to obtain the best signal.

Background

EPIC is a capacitive sensor and so does not rely on ohmic contact to the body for measuring bio-electrical signals. It therefore has the ability to measure ECG without direct skin contact. Signals measured on the human body always include a large amount of noise, the major component of this being 50 or 60 Hz power line noise capacitively coupled to the body from the mains electricity supply. Measurements such as ECG depend on being able to extract the small electrophysiological signals from the much larger noise signals.

When using EPIC in "contact mode" for ECG measurement, the subject touches both the capacitive electrode surface and some metal at the system ground directly with the skin. This ground reference allows filtering and differential amplification of signals from two sensors to be effective in removing the mains frequency noise, leaving a high quality ECG signal.

Basic configuration for non-contact ECG measurement including capacitively-coupled DRL" circuit.

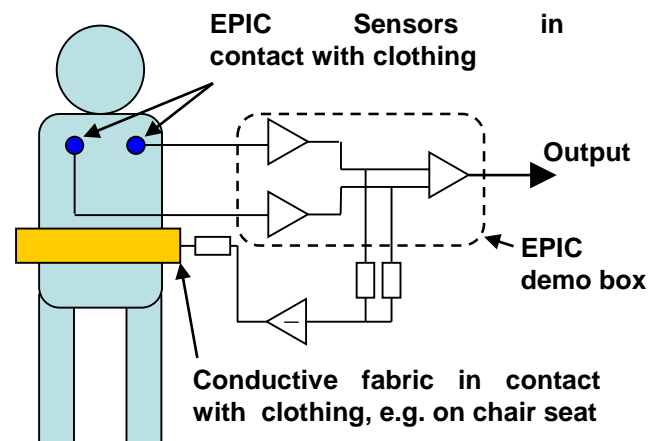

In non-contact ECG measurement there is – by definition - no skin contact, and thus no direct connection can be made between the subject's body and the system ground. Some other method of reducing the power line noise is therefore required to enable the ECG signal to be extracted reliably and accurately. One such method utilises an approach very similar to the Driven Right Leg (DRL) system that is used for the same purpose in conventional ECG. In conventional ECG the DRL signal is coupled directly to the patient's skin; in non-contact ECG it is coupled capacitively to the body, through clothing, via a piece of conductive material placed – for instance – on the seat or back of a chair. Capacitive coupling of DRL signals is described by Lim et al ¹ and Lee et al².

1. Settling time – When a subject first sits in the chair and leans against the EPIC sensors, the changes in electric potential will normally send both the sensors and the DRL circuit into saturation. Because the system contains some large impedances, and hence has some very long RC time constants, settling times of tens of seconds can be needed before a clean ECG signal is seen. During this period the signal can either appear very noisy, or be virtually flat, depending on whether one or both sensors, or the DRL circuit, are "railing". The subject should sit still during this time and wait for the circuit to settle, since continually adjusting position will only make matters worse. Settling times can sometimes be reduced by turning off the power to the demo box for a few seconds.

2. Clothing – Best results have been obtained when the material between the sensors and the skin is one or two layers of cotton material. This is therefore recommended as a starting point for system evaluation. Signals have also been measured successfully through other materials, including a wool-mix sweater and a polyester fleece in addition to two layers of cotton material. Examples are shown in figures 6 and 7. If the key parameter of interest is the "R-R" interval, adjustment of filter settings to reduce or re-centre the signal bandwidth can give significant improvement in signal quality.

3. Static – Because there is no direct physical contact between the subject and any grounding point, there is no path for any static build up to be discharged. Under most circumstances static build up does not present a problem, but depending on factors including clothing, footwear, flooring, humidity levels in the air and so forth, static build up can sometimes prevent the cardiac signal from being seen clearly. In this situation the subject should briefly touch something metal connected either to an external ground or to the system ground to discharge the static.

4. Cable shielding – The EPIC demo box grounds the shielding of the sensor cable via the connection between the outer casing of the sensor plugs and the metal surround of the socket on the box. Ensuring that this connection is well made will reduce unwanted noise artefacts from the signal.

[1] YG Lim, GS Chung, KS Park. "Capacitive Driven-right-leg Grounding in Indirect-contact ECG Measurement," 32nd Annual International Conference of the IEEE EMBS Buenos Aires, Argentina, August 31 - September 4, 2010 pp 1250-1253

[2] KM Lee, SM Lee, KS Sim, KK Kim, KS Park "Noise Reduction for Non-Contact Electrocardiogram Measurement in Daily Life," Computers in Cardiology

4.2 Datasheets

4.2.1 App Boards for EPIC sensor PS25201A/ PS25012A1,B1

Features

- Ultra high input resistance, typically $5 \times 10^{10} \Omega$.
- Frequency response (3dB) 200mHz to 4.0kHz.
- Wide operating voltage from 4.0 to 8.0V.
- Operating temperature range 0 to 50°C.
- 200pF load drive capability.
- Ground referenced output.
- DC signal rejection.
- Dual sensor board allows differential operation.

Applications

- Electrophysiological signal detection.
 - ECG/EOG/EMG/EEG
- Electric field and potential sensing.
 - Movement sensing

Description

The PS25012A1 and PS25012B1 are single and dual channel application boards for the demonstration of the Plessey PS25201A electric potential sensor.

The PS25201A electric potential sensors on these boards allow the measurement of a wide range of electric potential sources from electrophysiological signals through to spatial electric field. The sensors incorporate a DC block feature that allows the DC component of an applied signal to be rejected while maintaining good low frequency response. The electrode surface of the detector is passivated with a thin dielectric that allows the direct application to a test surface. In the case of contact with skin there is no need for electrically conductive gel.

The PS25201A sensor demonstrated on these boards is an integrated assembly designed for surface mount assembly on a motherboard.

The application boards provide the regulated +2.5V and generated -2.5V supplies that are used to operate the sensor. This allows the boards to demonstrate the sensors from a wide, single sided, power supply voltage while the output of the sensor can cover the range $\pm 2.1V$. The boards are connected by a high reliability five pin connector.

Two single channel PS25012A1 boards or a dual channel PS25012B1 board may be used to generate a differential signal. A typical example is shown in Figure 3 below:

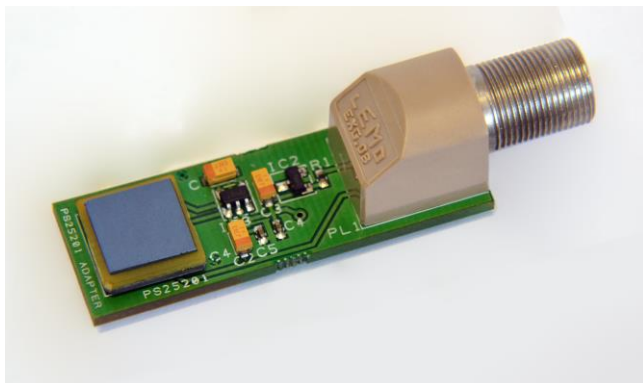

Figure 1: PS25012A1 single channel board carrying a single PS25201A sensor

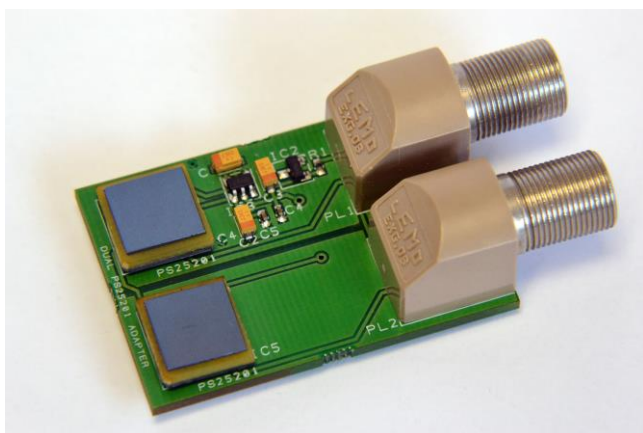

Figure 2: PS25012B1 dual channel board carrying two PS25201A sensors

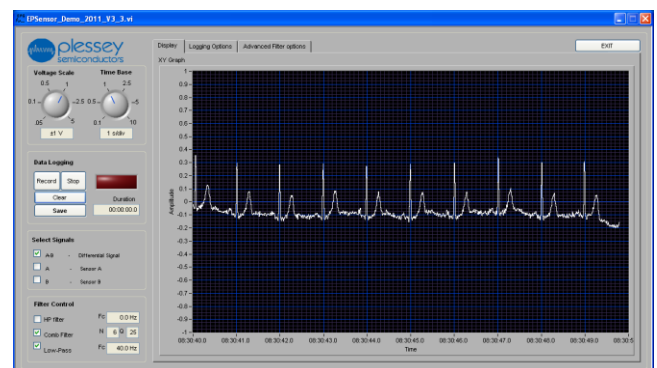

Figure 3: Differential signal from two sensors in contact with the skin showing ECG type characteristics

Electrical Characteristics

These electrical characteristics apply to the PS25012A1 and PS25012B1 application boards that carry the PS25201A sensors. The electrical characteristics (@25°C) are guaranteed by either production test or by design and characterisation. They apply within the specified supply voltage unless otherwise stated.

| Characteristics | Value | | | Units | Conditions/Notes |
|---------------------------|-------|-------|------|-------|---|
| | Min. | Typ. | Max. | | |
| Supply voltage | 4.0 | | 8.0 | V | Each PS25201A sensor consumes 2.0mA (typ). The additional current is consumed by the app'n board. Sensor to skin |
| Supply current; PS25012A1 | 2.7 | | 10.0 | mA | |
| Supply current; PS25012B1 | 5.4 | | 20.0 | mA | |
| Input resistance (Rin) | | 50 | | GΩ | |
| Input capacitance | | 10 | | pF | |
| Voltage Gain (Av) | | 50 | | | |
| Coupling capacitance | | 250 | | pF | |
| Lower 3dB point | | 0.200 | | Hz | |
| Upper 3dB point | | 4.0 | | kHz | |
| Noise | | tbd | | | |

Electrical Connector

The PS25012A1 and PS25012B1 application boards are fitted with one or two five pin sockets. The connectivity of these sockets is shown below:

| | |
|-------|----------|
| Pin 1 | Output |
| Pin 2 | Gnd |
| Pin 3 | Supply |
| Pin 4 | Gnd |
| Pin 5 | Not used |



The supply and ground connections of the two sockets on the dual channel PS25012B board are connected in parallel so that the board will be active with either one or both connectors in use. However, when both sockets are powered the supplied voltages must be identical.

Auxiliary Components

| | |
|----------|--|
| PS25000A | <u>Control and Interface Box; 50Hz.</u> This box provides power for one or two sensors. It incorporates switchable low pass and 50Hz notch filters. The box contains an amplifier with switchable gain of either x1 or x10. The box also generates a differential signal from two sensors. The box incorporates a data acquisition card that provides the data from the sensors via a USB cable to a computer. The box is powered by the USB connection. A soft scope is provided with this box for display of the signals on a computer. |
| PS25001A | <u>Control and Interface Box; 60Hz.</u> This box is identical to the PS25000A except that the switchable notch filter is preset to reject 60Hz. |
| PS25013 | <u>Adapter cable.</u> This 1.5m long cable connects the sockets of the PS25012A and PS25012B application boards to the PS25000A or PS25001A Control and Interface Box. |

4.2.2 App Boards for EPIC sensor PS25202/ PS252012A2,B2

Features

- Ultra high input resistance, typically $5 \times 10^{10} \Omega$.
- Frequency response (-3dB) 50mHz to 4.0kHz.
- Wide operating voltage from 4.0 to 8.0V.
- Operating temperature range 0 to 50°C.
- 200pF load drive capability.
- Ground referenced output.
- DC signal rejection.
- Dual sensor board allows differential operation.

Applications

- Electrophysiological signal detection.
 - ECG/EOG/EMG/EEG
- Electric field and potential sensing.
 - Movement sensing

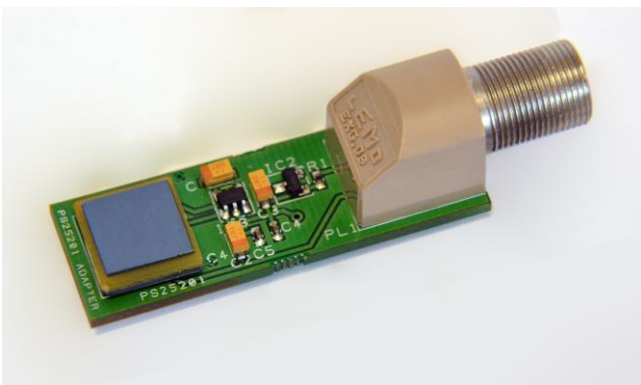

Figure 1: PS25012A2 single channel board carrying a single PS25202 sensor

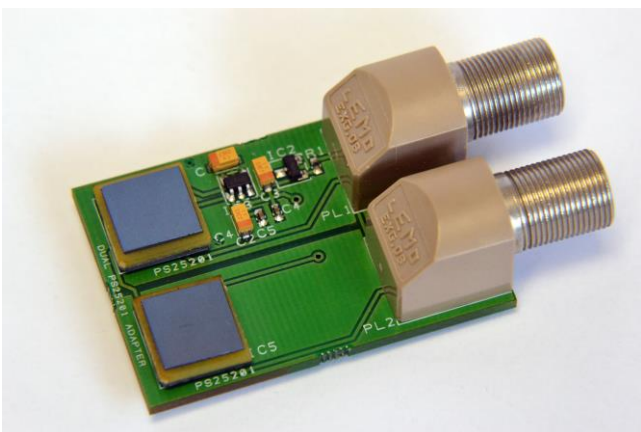

Figure 2: PS25012B2 dual channel board carrying two PS25202 sensors

Description

The PS25012A2 and PS25012B2 are single and dual channel application boards for the demonstration of the Plessey PS25202 electric potential sensor.

The PS25202 electric potential sensors on these boards allow the measurement of a wide range of electric potential sources from electrophysiological signals through to spatial electric field. The sensors incorporate a DC block feature that allows the DC component of an applied signal to be rejected while maintaining good low frequency response. The electrode surface of the detector is passivated with a thin dielectric that allows the direct application to a test surface. In the case of contact with skin there is no need for electrically conductive gel.

The PS25202 sensor demonstrated on these boards is an integrated assembly designed for surface mount assembly on a motherboard.

The application boards provide the regulated +2.5V and generated -2.5V supplies that are used to operate the sensor. This allows the boards to demonstrate the sensors from a wide, single sided, power supply voltage while the output of the sensor can cover the range $\pm 2.1V$. The boards are connected by a high reliability five pin connector.

Two single channel PS25012A2 boards or a dual channel PS25012B2 board may be used to generate a differential signal. A typical example is shown in Figure 3 below:

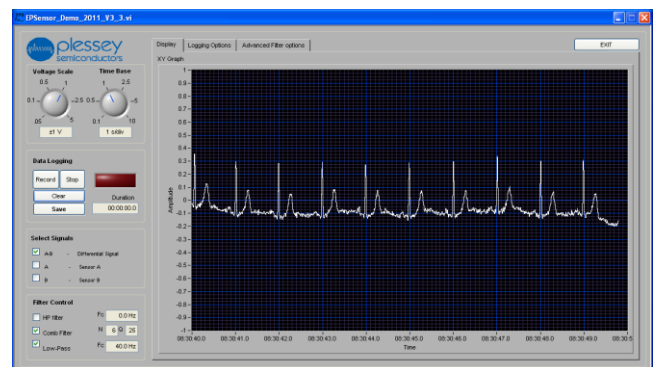

Figure 3: Differential signal from two sensors in contact with the skin showing ECG type characteristics

Electrical Characteristics

These electrical characteristics apply to the PS25012A2 and PS25012B2 application boards that carry the PS25202 sensors. The electrical characteristics (@25°C) are guaranteed by either production test or by design and characterisation. They apply within the specified supply voltage unless otherwise stated.

| Characteristics | Value | | | Units | Conditions/Notes |
|---------------------------|-------|------|------|-------|---|
| | Min. | Typ. | Max. | | |
| Supply voltage | 4.0 | | 8.0 | V | Each PS25202 sensor consumes 2.0mA (typ). The additional current is consumed by the app'n Sensor to skin |
| Supply current; PS25012A2 | 2.7 | | 10.0 | mA | |
| Supply current; PS25012B2 | 5.4 | | 20.0 | mA | |
| Input resistance (Rin) | | 50 | | GΩ | |
| Input capacitance | | 10 | | pF | |
| Voltage Gain (Av) | | 50 | | | |
| Coupling capacitance | | 250 | | pF | |
| Lower -3dB point | | 0.05 | | Hz | |
| Upper -3dB point | | 4.0 | | kHz | |
| Noise | | tbd | | | |

Electrical Connector

The PS25012A2 and PS25012B2 application boards are fitted with one or two five pin sockets. The connectivity of these sockets is shown below:

| | |
|-------|----------|
| Pin 1 | Output |
| Pin 2 | Gnd |
| Pin 3 | Supply |
| Pin 4 | Gnd |
| Pin 5 | Not used |



The supply and ground connections of the two sockets on the dual channel PS25012B2 board are connected in parallel so that the board will be active with either one or both connectors in use. However, when both sockets are powered the supplied voltages must be identical.

Auxiliary Components

- PS25000A Control and Interface Box; 50Hz.
This box provides power for one or two sensors. It incorporates switchable low pass and 50Hz notch filters. The box contains an amplifier with switchable gain of either x1 or x10. The box also generates a differential signal from two sensors. The box incorporates a data acquisition card that provides the data from the sensors via a USB cable to a computer. The box is powered by the USB connection. A soft scope is provided with this box for display of the signals on a computer.
- PS25001A Control and Interface Box; 60Hz.
This box is identical to the PS25000A except that the switchable notch filter is preset to reject 60Hz.
- PS25013 Adapter cable.
This 1.5m long cable connects the sockets of the PS25012A2 and PS25012B2 application boards to the PS25000A or PS25001A Control and Interface Box.

4.2.3 App Boards for EPIC sensor PS25012A3,B3

Features

- Ultra high input resistance, typically $5 \times 10^{10} \Omega$.
- Frequency response (-3dB) 200mHz to 20kHz.
- Wide operating voltage from 4.0 to 8.0V.
- Operating temperature range 0 to 50°C.
- 200pF load drive capability.
- Ground referenced output.
- DC signal rejection.
- Dual sensor board allows differential operation.

Applications

- Electrophysiological signal detection.
- ECG/EOG/EMG/EEG
- Electric field and potential sensing.
- Movement sensing

Description

The PS25012A3 and PS25012B3 are single and dual channel application boards for the demonstration of the Plessey PS25203 electric potential sensor.

The PS25203 electric potential sensors on these boards allow the measurement of a wide range of electric potential sources from electrophysiological signals through to spatial electric field. The sensors incorporate a DC block feature that allows the DC component of an applied signal to be rejected while maintaining good low frequency response. The electrode surface of the detector is passivated with a thin dielectric that allows the direct application to a test surface. In the case of contact with skin there is no need for electrically conductive gel.

The PS25203 sensor demonstrated on these boards is an integrated assembly designed for surface mount assembly on a motherboard.

The application boards provide the regulated +2.5V and generated -2.5V supplies that are used to operate the sensor. This allows the boards to demonstrate the sensors from a wide, single sided, power supply voltage while the output of the sensor can cover the range $\pm 2.1V$. The boards are connected by a high reliability five pin connector.

Two single channel PS25012A3 boards or a dual channel PS25012B3 board may be used to generate a differential signal. A typical example is shown in

Figure 3 below:

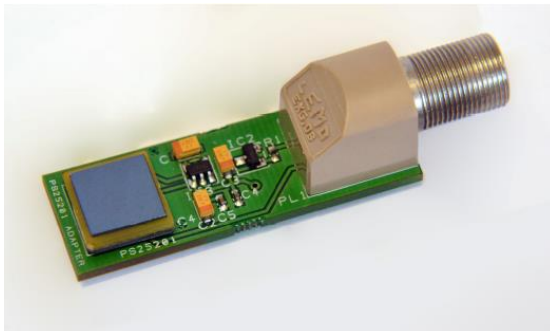

Figure 1: PS25012A3 single channel board carrying a single PS25203 sensor

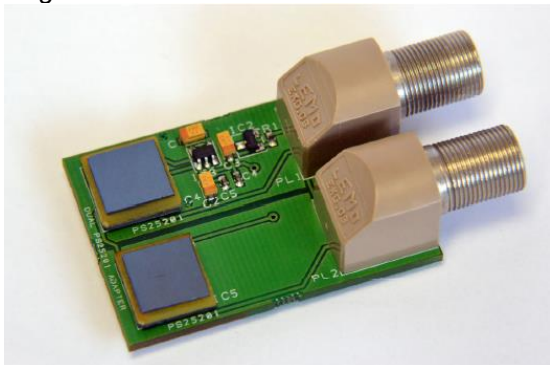

Figure 2: PS25012B3 dual channel board carrying two PS25203 sensors

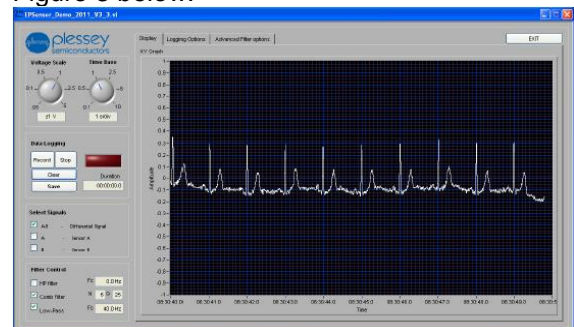

Figure 3: Differential signal from two sensors in contact with the skin showing ECG type characteristics

Electrical Characteristics

These electrical characteristics apply to the PS25012A3 and PS25012B3 application boards that carry the PS25203 sensors. The electrical characteristics (@25°C) are guaranteed by either production test or by design and characterisation. They apply within the specified supply voltage unless otherwise stated.

| Characteristics | Value | | | Units | Conditions/Notes |
|---------------------------|-------|------|------|-------|--|
| | Min. | Typ. | Max. | | |
| Supply voltage | 4.0 | | 8.0 | V | Each PS25203 sensor consumes 2.0mA (typ). The additional current is consumed by the app'n board. Sensor to skin |
| Supply current; PS25012A3 | 2.7 | | 10.0 | mA | |
| Supply current; PS25012B3 | 5.4 | | 20.0 | mA | |
| Input resistance (Rin) | | 50 | | GΩ | |
| Input capacitance | | 10 | | pF | |
| Voltage Gain (Av) | | 10 | | | |
| Coupling capacitance | | 250 | | pF | |
| Lower -3dB point | | 0.20 | | Hz | |
| Upper -3dB point | | 20.0 | | kHz | |
| Noise | | tbd | | | |

Electrical Connector

The PS25012A3 and PS25012B3 application boards are fitted with one or two five pin sockets. The connectivity of these sockets is shown below:

- Pin 1 Output
- Pin 2 Gnd
- Pin 3 Supply
- Pin 4 Gnd
- Pin 5 Not used



The supply and ground connections of the two sockets on the dual channel PS25012B3 board are connected in parallel so that the board will be active with either one or both connectors in use. However, when both sockets are powered the supplied voltages must be identical.

Auxiliary Components

PS25000A Control and Interface Box; 50Hz.

This box provides power for one or two sensors. It incorporates switchable low pass and 50Hz notch filters. The box contains an amplifier with switchable gain of either x1 or x10. The box also generates a differential signal from two sensors. The box incorporates a data acquisition card that provides the data from the sensors via a USB cable to a computer. The box is powered by the USB connection. A soft scope is provided with this box for display of the signals on a computer.

PS25001A Control and Interface Box; 60Hz.

This box is identical to the PS25000A except that the switchable notch filter is preset to reject 60Hz.

PS25013 Adapter cable.

This 1.5m long cable connects the sockets of the PS25012A3 and PS25012B3 application boards to the PS25000A or PS25001A Control and Interface Box.

4.2.4 App Boards for EPIC sensor PS25204/ PS25012A4,B4

Features

- Ultra high input resistance, typically $5 \times 10^{10} \Omega$.
- Frequency response (-3dB) 50mHz to 20kHz.
- Wide operating voltage from 4.0 to 8.0V.
- Operating temperature range 0 to 50°C.
- 200pF load drive capability.
- Ground referenced output.
- DC signal rejection.
- Dual sensor board allows differential operation.

Applications

- Electrophysiological signal detection.
 - ECG/EOG/EMG/EEG
- Electric field and potential sensing.
 - Movement sensing

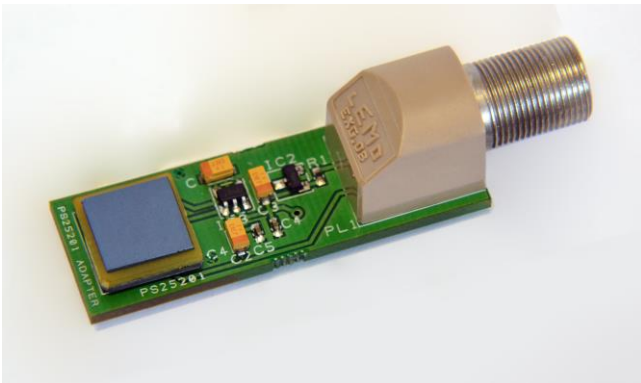

Figure 1: PS25012A4 single channel board carrying a single PS25204 sensor

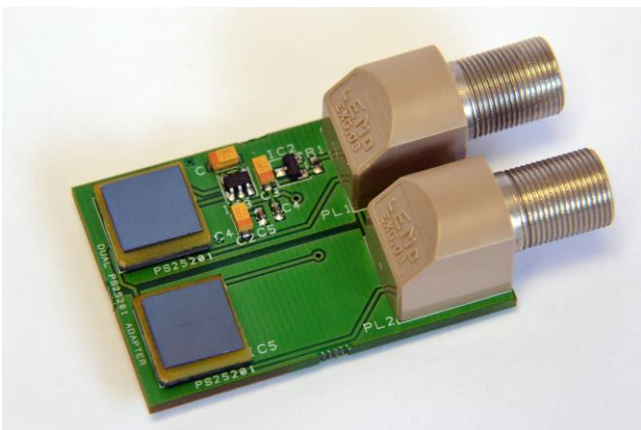

Figure 2: PS25012B4 dual channel board carrying two PS25204 sensors

Description

The PS25012A4 and PS25012B4 are single and dual channel application boards for the demonstration of the Plessey PS25204 electric potential sensor.

The PS25204 electric potential sensors on these boards allow the measurement of a wide range of electric potential sources from electrophysiological signals through to spatial electric field. The sensors incorporate a DC block feature that allows the DC component of an applied signal to be rejected while maintaining good low frequency response. The electrode surface of the detector is passivated with a thin dielectric that allows the direct application to a test surface. In the case of contact with skin there is no need for electrically conductive gel.

The PS25204 sensor demonstrated on these boards is an integrated assembly designed for surface mount assembly on a motherboard.

The application boards provide the regulated +2.5V and generated -2.5V supplies that are used to operate the sensor. This allows the boards to demonstrate the sensors from a wide, single sided, power supply voltage while the output of the sensor can cover the range $\pm 2.1V$. The boards are connected by a high reliability five pin connector.

Two single channel PS25012A4 boards or a dual channel PS25012B4 board may be used to generate a differential signal. A typical example is shown in Figure 3 below:

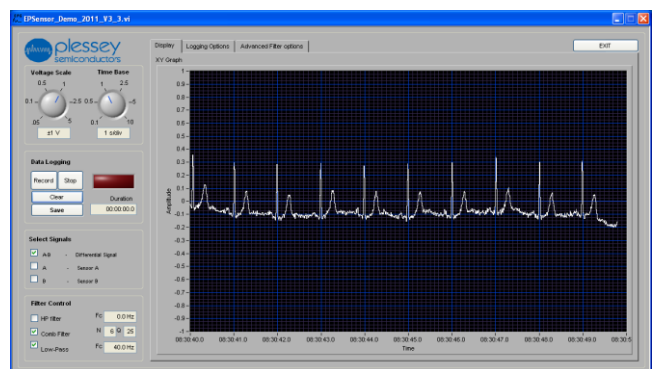

Figure 3: Differential signal from two sensors in contact with the skin showing ECG type characteristics

Electrical Characteristics

These electrical characteristics apply to the PS25012A4 and PS25012B4 application boards that carry the PS25204 sensors. The electrical characteristics (@25°C) are guaranteed by either production test or by design and characterisation. They apply within the specified supply voltage unless otherwise stated.

| Characteristics | Value | | | Units | Conditions/Notes |
|-------------------------------------|-------|------|------|-------|---|
| | Min. | Typ. | Max. | | |
| Supply voltage | 4.0 | | 8.0 | V | Each PS25204 sensor consumes 2.0mA (typ). The additional current is consumed by the app'n Sensor to skin |
| Supply current; PS25012A4 | 2.7 | | 10.0 | mA | |
| Supply current; PS25012B4 | 5.4 | | 20.0 | mA | |
| Input resistance (R _{in}) | | 50 | | GΩ | |
| Input capacitance | | 10 | | pF | |
| Voltage Gain (A _v) | | 10 | | | |
| Coupling capacitance | | 250 | | pF | |
| Lower -3dB point | | 0.05 | | Hz | |
| Upper -3dB point | | 20.0 | | kHz | |
| Noise | | tbd | | | |

Electrical Connector

The PS25012A4 and PS25012B4 application boards are fitted with one or two five pin sockets. The connectivity of these sockets is shown below:

| | |
|-------|----------|
| Pin 1 | Output |
| Pin 2 | Gnd |
| Pin 3 | Supply |
| Pin 4 | Gnd |
| Pin 5 | Not used |



The supply and ground connections of the two sockets on the dual channel PS25012B4 board are connected in parallel so that the board will be active with either one or both connectors in use. However, when both sockets are powered the supplied voltages must be identical.

Auxiliary Components

- PS25000A Control and Interface Box; 50Hz.
This box provides power for one or two sensors. It incorporates switchable low pass and 50Hz notch filters. The box contains an amplifier with switchable gain of either x1 or x10. The box also generates a differential signal from two sensors. The box incorporates a data acquisition card that provides the data from the sensors via a USB cable to a computer. The box is powered by the USB connection. A soft scope is provided with this box for display of the signals on a computer.
- PS25001A Control and Interface Box; 60Hz.
This box is identical to the PS25000A except that the switchable notch filter is preset to reject 60Hz.
- PS25013 Adapter cable.
This 1.5m long cable connects the sockets of the PS25012A4 and PS25012B4 application boards to the PS25000A or PS25001A Control and Interface Box.

4.2.5 App Boards for EPIC sensor PS25401A/ PS25014A1,B1

Features

- Ultra high effective input impedance, typically 20GΩ.
- Wide operating voltage from 4.0 to 8.0V.
- Operating temperature range 0 to 50°C.
- 200pF load drive capability.
- Ground referenced output.
- DC signal rejection.
- Dual sensor board allows differential operation.

Applications

- Movement sensing due to electric field disturbance
- Electric field and potential sensing.

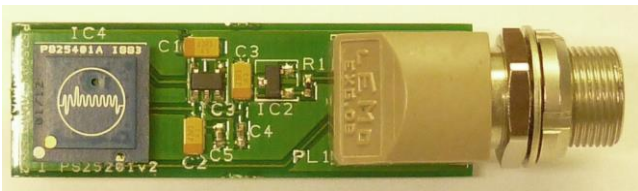

Figure 1: PS25014A1 single channel board carrying a single PS25401A sensor

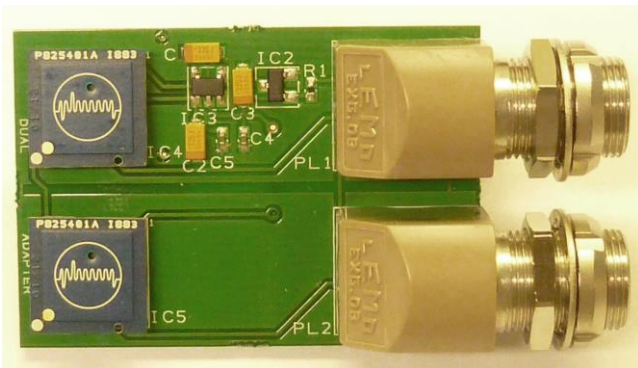

Figure 2: PS25014B1 dual channel board carrying two PS25401A sensors

Description

The PS25014A1 and PS25014B1 are single and dual channel application boards for the demonstration of the Plessey PS25401A electric potential sensor.

The PS25401A electric potential sensors on these boards allow the measurement of a wide range of electric potential sources. Two sensors may be used differentially to determine electric field. The sensors incorporate a DC block feature that allows the DC component of an applied signal to be rejected while maintaining good low frequency response. The electrode surface of the detector is passivated with an inert dielectric that provides environmental protection. These sensors are not intended for direct coupling to the surface of the skin. In the case of electrophysiological sensing the following sensors should be used:

| ECG Sensor | -3dB bandwidth mHz | Voltage gain | Application Boards Single/Dual |
|------------|--------------------|--------------|--------------------------------|
| PS25201 | 200 | 50 | PS25012A PS25012B |
| PS25201A | 200 | 50 | PS25012A1 PS25012B1 |
| PS25202 | 50 | 50 | PS25012A2 PS25012B2 |
| PS25203 | 200 | 10 | PS25012A3 PS25012B3 |
| PS25204 | 50 | 10 | PS25012A4 PS25012B4 |

The PS25401A sensor demonstrated on these boards is an integrated assembly designed for surface mount assembly on a motherboard.

The application boards provide a regulated +2.5V and generated -2.5V supplies that are used to operate the sensor. This allows the boards to demonstrate the sensors from a wide, single sided, power supply voltage while the output of the sensor can cover the range $\pm 2.1V$. The boards are connected by a high reliability five pin connector.

Electrical Characteristics

These electrical characteristics apply to the PS25014A1 and PS25014B1 application boards that carry the PS25401A sensors. The electrical characteristics (@25°C) are guaranteed by either production test or by design and characterisation. They apply within the specified supply voltage unless otherwise stated.

| Characteristics | Value | | | Units | Conditions/Notes |
|-----------------------------|-------|------|------|-------|--|
| | Min. | Typ. | Max. | | |
| Supply voltage | 4.0 | | 8.0 | V | Each PS25401A sensor consumes 2.0mA (typ). The additional current is consumed by |
| Supply current; PS25014A1 | 2.7 | | 10.0 | mA | |
| Supply current; PS25014B1 | 5.4 | | 20.0 | mA | |
| Effective input impedance | | 20 | tbd | GΩ | |
| Effective input capacitance | | 15 | | pF | |
| Voltage Gain (Av) | | 50 | | | |
| Noise | | tbd | | | |

Electrical Connector

The PS25014A1 and PS25014B1 application boards are fitted with one or two five pin sockets. The connectivity of these sockets is shown below:

| | |
|-------|----------|
| Pin 1 | Output |
| Pin 2 | Gnd |
| Pin 3 | Supply |
| Pin 4 | Gnd |
| Pin 5 | Not used |



The supply and ground connections of the two sockets on the dual channel PS25014B1 board are connected in parallel so that the board will be active with either one or both connectors in use. However, when both sockets are powered the supplied voltages must be identical.

Auxiliary Components

| | |
|----------|--|
| PS25000A | <u>Control and Interface Box; 50Hz.</u> This box provides power for one or two sensors. It incorporates switchable low pass and 50Hz notch filters. The box contains an amplifier with switchable gain of either x1 or x10. The box also generates a differential signal from two sensors. The box incorporates a data acquisition card that provides the data from the sensors via a USB cable to a computer. The box is powered by the USB connection. A soft scope is provided with this box for display of the signals on a computer. |
| PS25001A | <u>Control and Interface Box; 60Hz.</u> This box is identical to the PS25000A except that the switchable notch filter is preset to reject 60Hz. |
| PS25013 | <u>Adapter cable.</u> This 1.5m long cable connects the sockets of the EPIC application boards to the PS25000A or PS25001A Control and Interface Box. |

4.2.6 App Boards for EPIC sensor PS25402/ PS25014A2.B2

Features

- Ultra high effective input impedance, typically 20GΩ.
- Wide operating voltage from 4.0 to 8.0V.
- Operating temperature range 0 to 50°C.
- 200pF load drive capability.
- Ground referenced output.
- DC signal rejection.
- Dual sensor board allows differential operation.

Applications

- Movement sensing due to electric field disturbance
- Electric field and potential sensing.

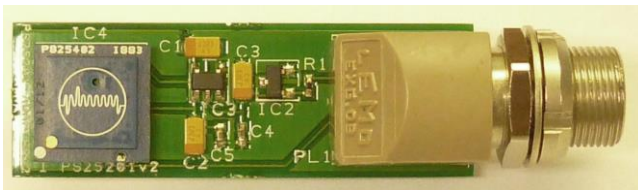

Figure 1: PS25014A2 single channel board carrying a single PS25402 sensor

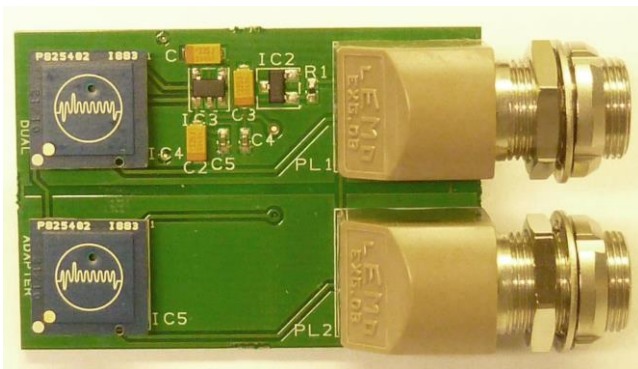

Figure 2: PS25014B2 dual channel board carrying two PS25402 sensors

Description

The PS25014A2 and PS25014B2 are single and dual channel application boards for the demonstration of the Plessey PS25402 electric potential sensor.

The PS25402 electric potential sensors on these boards allow the measurement of a wide range of electric potential sources. Two sensors may be used differentially to determine electric field. The sensors incorporate a DC block feature that allows the DC component of an applied signal to be rejected while maintaining good low frequency response. The electrode surface of the detector is passivated with an inert dielectric that provides environmental protection. These sensors are not intended for direct coupling to the surface of the skin. In the case of electrophysiological sensing the following sensors should be used:

| ECG Sensor | -3dB bandwidth mHz | Voltage gain | Application Boards Single/Dual |
|------------|--------------------|--------------|--------------------------------|
| PS25201 | 200 | 50 | PS25012A PS25012B |
| PS25201A | 200 | 50 | PS25012A1 PS25012B1 |
| PS25202 | 50 | 50 | PS25012A2 PS25012B2 |
| PS25203 | 200 | 10 | PS25012A3 PS25012B3 |
| PS25204 | 50 | 10 | PS25012A4 PS25012B4 |

The PS25402 sensor demonstrated on these boards is an integrated assembly designed for surface mount assembly on a motherboard.

The application boards provide a regulated +2.5V and generated -2.5V supplies that are used to operate the sensor. This allows the boards to demonstrate the sensors from a wide, single sided, power supply voltage while the output of the sensor can cover the range $\pm 2.1V$. The boards are connected by a high reliability five pin connector.

Electrical Characteristics

These electrical characteristics apply to the PS25014A2 and PS25014B2 application boards that carry the PS25402 sensors. The electrical characteristics (@25°C) are guaranteed by either production test or by design and characterisation. They apply within the specified supply voltage unless otherwise stated.

| Characteristics | Value | | | Units | Conditions/Notes |
|-----------------------------|-------|------|------|-------|---|
| | Min. | Typ. | Max. | | |
| Supply voltage | 4.0 | | 8.0 | V | Each PS25402 sensor consumes 2.0mA (typ). The additional current is consumed by the app'n |
| Supply current; PS25014A2 | 2.7 | | 10.0 | mA | |
| Supply current; PS25014B2 | 5.4 | | 20.0 | mA | |
| Effective input resistance | | 20 | tbd | GΩ | |
| Effective input capacitance | | 15 | | pF | |
| Voltage Gain (Av) | | 10 | | | |
| Noise | | tbd | | | |

Electrical Connector

The PS25014A2 and PS25014B2 application boards are fitted with one or two five pin sockets. The connectivity of these sockets is shown below:

- Pin 1 Output
- Pin 2 Gnd
- Pin 3 Supply
- Pin 4 Gnd
- Pin 5 Not used



The supply and ground connections of the two sockets on the dual channel PS25014B2 board are connected in parallel so that the board will be active with either one or both connectors in use. However, when both sockets are powered the supplied voltages must be identical.

Auxiliary Components

- PS25000A Control and Interface Box; 50Hz.
This box provides power for one or two sensors. It incorporates switchable low pass and 50Hz notch filters. The box contains an amplifier with switchable gain of either x1 or x10. The box also generates a differential signal from two sensors. The box incorporates a data acquisition card that provides the data from the sensors via a USB cable to a computer. The box is powered by the USB connection. A soft scope is provided with this box for display of the signals on a computer.
- PS25001A Control and Interface Box; 60Hz.
This box is identical to the PS25000A except that the switchable notch filter is preset to reject 60Hz.
- PS25013 Adapter cable.
This 1.5m long cable connects the sockets of the EPIC application boards to the PS25000A or PS25001A Control and Interface Box.

4.2.7 EPIC Ultra High Impedance ECG Sensor Advance Info PS25101

FEATURES

- Ultra high input resistance, typically $2 \times 10^{10} \Omega$
- Dry-contact capacitive coupling
- Input capacitance as low as 10pF
- Upper -3dB point typically 10kHz
- Lower -3dB point typically 100mHz
- Operates with single +4.75V to 8.0V supply
- Sensors supplied as custom engineered probe assemblies complete with connecting lead and DIN plug termination

APPLICATIONS

- Non-critical patient monitoring equipment
- Emergency response diagnostics
- Lifestyle sports and health products
- Suitable for long-term and remote monitoring

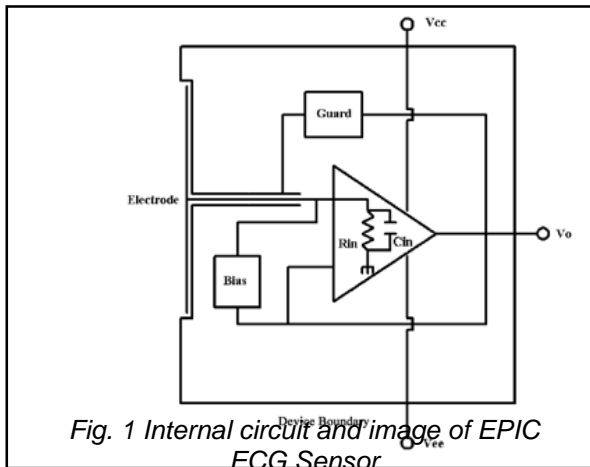

PS25101
Custom package

0°C to +50°C

Plessey Semiconductors Electric Potential Integrated Circuit (EPIC) product line targets a range of applications.

The PS25101 is an ultra high impedance solid state ECG (electrocardiograph) sensor. It can be used as a dry contact ECG sensor without the need for potentially dangerous low impedance circuits across the heart. The resolution available is as good as or better than conventional wet electrodes.

The device uses active feedback techniques to both lower the effective input capacitance of the sensing element (C_{in}) and boost the input resistance (R_{in}). These techniques are used to realise a sensor with a frequency response suitable for both diagnostic and monitoring ECG applications. The total voltage gain of the system is a function of both the input coupling capacitance (variable) and the internal sensor configuration.



ELECTRICAL CHARACTERISTICS

$T_{amb} = 0^{\circ}\text{C}$ to $+50^{\circ}\text{C}$, $V_{dd} = +5\text{v}$. The electrical characteristics are guaranteed by either production test or by design and characterisation. They apply within the specified ambient temperature and supply voltage unless otherwise stated.

| Characteristics | Value | | | Units | Conditions |
|---|-------|------|------|------------|--|
| | Min. | Typ. | Max. | | |
| Supply (Vdd) | +4.75 | 5.00 | 8.0 | | Unipolar ($V_{ss}=0\text{v}$) |
| Supply current | | 4.5 | | mA | @Vdd=5.0V |
| Voltage Gain (A_v) | | 50 | | | Peak-to-peak |
| Effective input resistance (R_{ine}) | | 20 | | G Ω | |
| Effective input capacitance (C_{ine}) | | 15 | | pF | |
| Coupling capacitance | | 1 | | nF | Sensor to skin |
| Lower -3dB point | | 100 | | mHz | Set by internal DC signal rejection network – coupling capacitor 1nF |
| Upper -3dB point | | 10 | | kHz | |
| Noise | | tbd | | | |
| Output voltage swing | -2.4 | | 2.4 | V | Output signal can swing negative and positive and is centred on 0V |

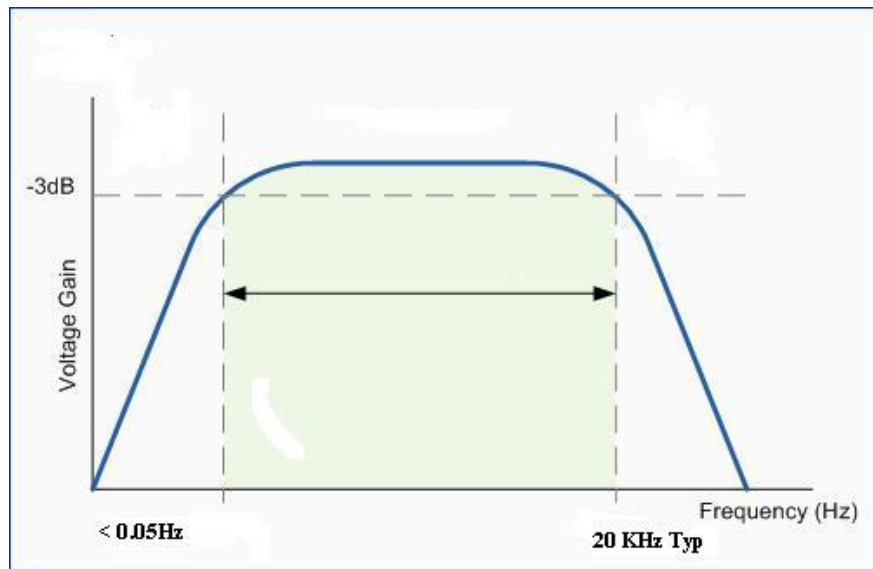

Fig. 2 Typical Bode Plot for EPIC ECG Sensor

4 PIN DIN PLUG TERMINATION



| | |
|------|---------------|
| Pin1 | Signal Out |
| | (Yellow) |
| Pin2 | Earth (Green) |

APPLICATION OF THE ECG SENSOR

Because of the large coupling capacitance to the body (around 1nF) the EPIC sensor's internal electrometer can be used in differential mode to recover true surface potential ECG signals from the surface of the skin.

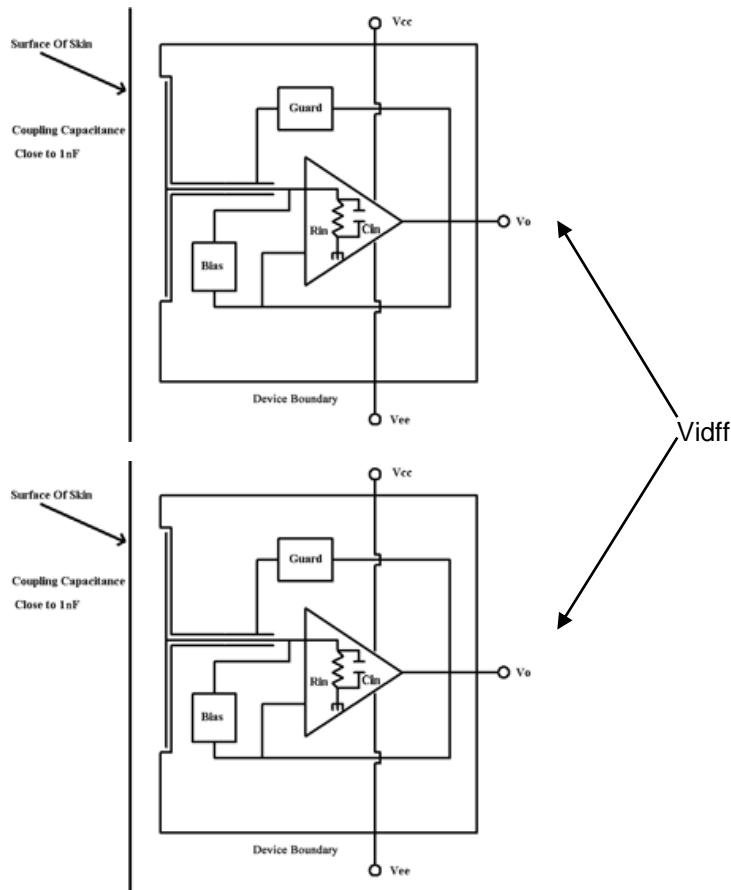

Fig. 3 Differential measurement of body (skin) surface potential to produce ECG trace



Fig. 4 Comparison of two ECG vectors from a pair of EPIC sensors (top) and two conventional Ag/AgCl electrodes (bottom)

4.2.8 EPIC Ultra High Impedance ECG Sensor Advance Info PS25102

FEATURES

- Ultra high input resistance, typically $2 \times 10^{10} \Omega$
- Dry-contact capacitive coupling
- Input capacitance as low as 10pF
- Upper -3dB point typically 10kHz
- Lower -3dB point typically 100mHz
- Operates with single +4.75V to 8.0V supply
- Sensors supplied as custom engineered probe assemblies complete with connecting lead and DIN plug termination

APPLICATIONS

- Non-critical patient monitoring equipment
- Emergency response diagnostics
- Lifestyle sports and health products
- Suitable for long-term and remote monitoring

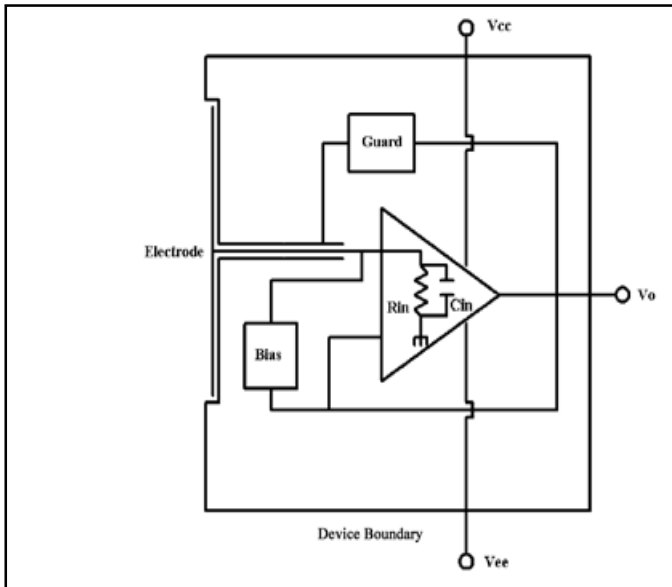

Internal circuit and image of EPIC ECG Sensor

PS25102
Custom package

0°C to +50°C

Plessey Semiconductors Electric Potential Integrated Circuit (EPIC) product line targets a range of applications.

The PS25102 is an ultra high impedance solid state ECG (electrocardiograph) sensor. It can be used as a dry contact ECG sensor without the need for potentially dangerous low impedance circuits across the heart. The resolution available is as good as or better than conventional wet electrodes.

The device uses active feedback techniques to both lower the effective input capacitance of the sensing element (C_{in}) and boost the input resistance (R_{in}). These techniques are used to realise a sensor with a frequency response suitable for both diagnostic and monitoring ECG applications. The total voltage gain of the system is a function of both the input coupling capacitance (variable) and the internal sensor configuration.

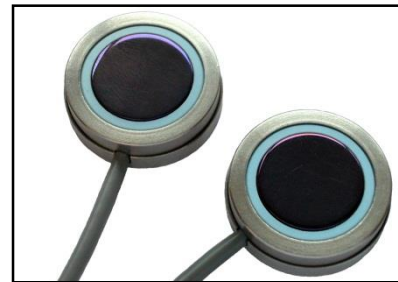

ELECTRICAL CHARACTERISTICS

$T_{amb} = 0^{\circ}\text{C}$ to $+50^{\circ}\text{C}$, $V_{dd} = +5\text{v}$. The electrical characteristics are guaranteed by either production test or by design and characterisation. They apply within the specified ambient temperature and supply voltage unless otherwise stated.

| Characteristics | Value | | | Units | Conditions |
|---|-------|------|------|------------|---|
| | Min. | Typ. | Max. | | |
| Supply (Vdd) | +4.75 | 5.00 | 8.0 | | Unipolar ($V_{ss}=0\text{v}$) @ $V_{dd}=5.0\text{V}$ Peak-to-peak Sensor to skin Set by internal DC signal rejection network – coupling capacitor 1nF |
| Supply current | | 4.5 | | mA | |
| Voltage Gain (A_v) | | 10 | | | |
| Effective input resistance (R_{ine}) | | 20 | | G Ω | |
| Effective input capacitance (C_{ine}) | | 15 | | pF | |
| Coupling capacitance | | 1 | | nF | |
| Lower -3dB point | | 100 | | mHz | |
| Upper -3dB point | | 10 | | kHz | |
| Noise | | tbd | | | |
| Output voltage swing | -2.4 | | 2.4 | V | |

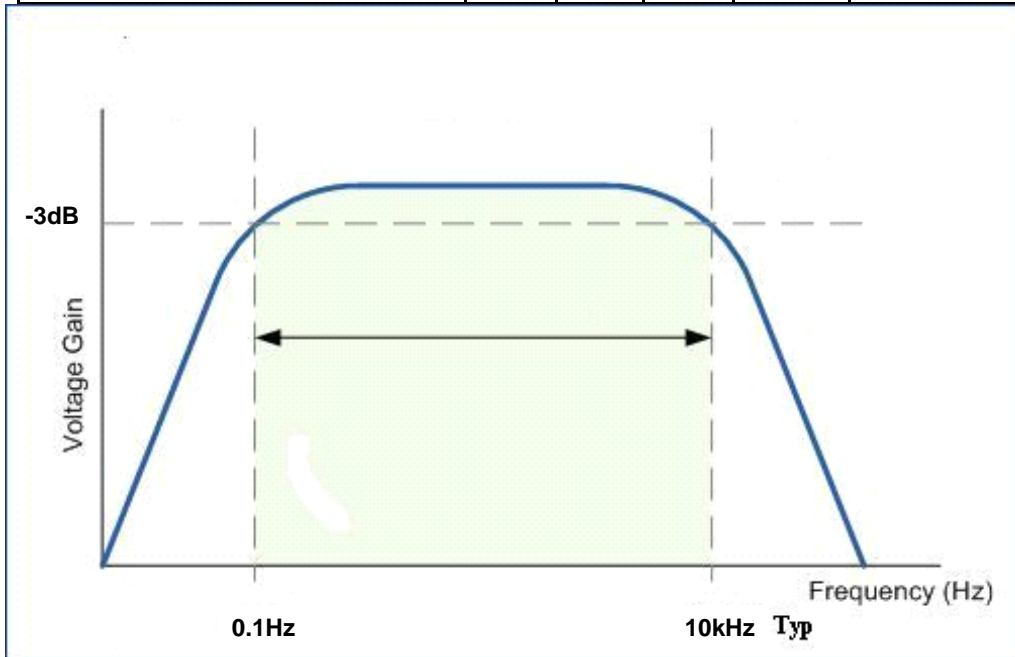

Fig. 2 Typical Bode Plot for EPIC ECG Sensor

4 PIN DIN PLUG TERMINATION



Pin1 Signal Out (Yellow)
Pin2 Earth (Green)
Pin3 +6V (Red)
Pin4 0V (Blue)

Pin1 Signal Out (Yellow)
Pin2 Earth (Green)

APPLICATION OF THE ECG SENSOR

Because of the large coupling capacitance to the body (around 1nF) the EPIC sensor's internal electrometer can be used in differential mode to recover true surface potential ECG signals from the surface of the skin.

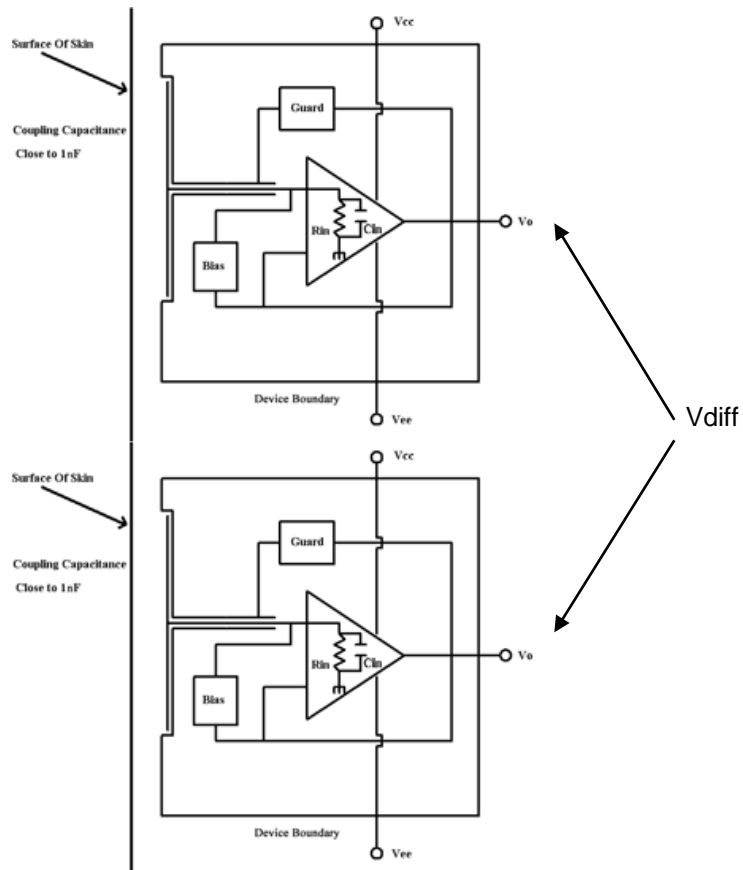

Fig. 3 Differential measurement of body (skin) surface potential to produce ECG trace



Fig. 4 Comparison of two ECG vectors from a pair of EPIC sensors (top) and two conventional Ag/AgCl electrodes (bottom)

4.2.9 EPIC Ultra High Impedance Electrophysiological Sensor/ PS25201A/B

FEATURES

- Ultra high input resistance, typically 20GΩ.
- Dry-contact capacitive coupling.
- Input capacitance as low as 15pF.
- Lower -3dB point typically 200mHz.
- Upper -3dB point typically 10kHz.
- Operates with bipolar power supply from $\pm 2.4V$ to $\pm 5.5V$.
- Sensors supplied in a custom package with exposed pins for surface mount assembly.

APPLICATIONS

- Contact ECG signal detection for:
 - Non-critical patient monitoring equipment.
 - Emergency response diagnostics.
 - Lifestyle sports and health products.

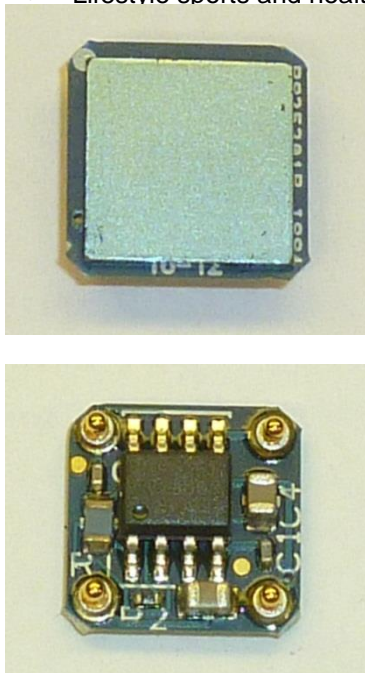
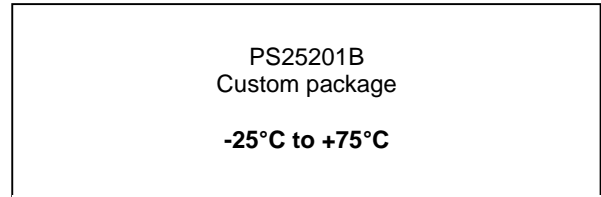

Fig. 1 PS25201B - Top and Bottom



Plessey Semiconductors Electric Potential Integrated Circuit (EPIC) product line targets a range of applications.

The PS25201B is an ultra-high impedance solid state ECG (electrocardiograph) sensor. It can be used as a dry contact ECG sensor without the need for potentially dangerous low impedance circuits across the heart. The resolution available is as good as or better than conventional wet electrodes.

The device uses active feedback techniques to both lower the effective input capacitance of the sensing element (C_{in}) and boost the input resistance (R_{in}). These techniques are used to realise a sensor with a frequency response suitable for both diagnostic and monitoring ECG

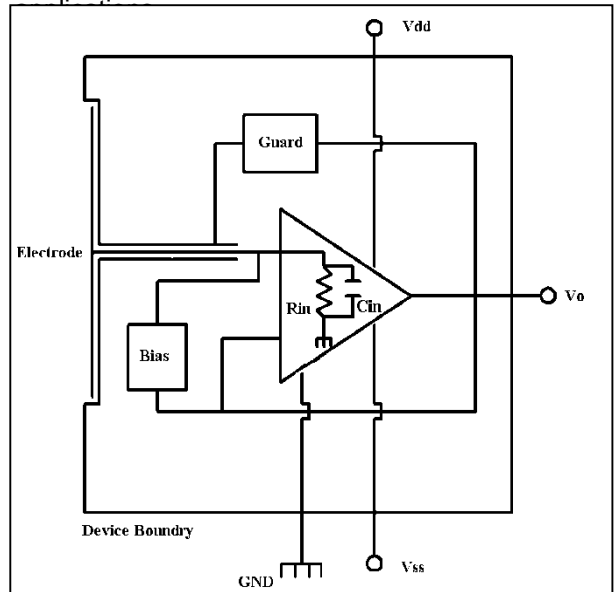

Fig. 2 Internal circuit of EPIC ECG Sensor

ELECTRICAL CHARACTERISTICS

$T_{amb} = -25^{\circ}\text{C}$ to $+75^{\circ}\text{C}$, $V_{dd}/V_{ss} \pm 2.4\text{V}$ to $\pm 5.5\text{V}$. The electrical characteristics are guaranteed by either production test or by design and characterisation. They apply within the specified ambient temperature and supply voltage unless otherwise stated.

| Characteristics | Value | | | Units | Conditions |
|-----------------------------|-----------|------|-----------|------------|---|
| | Min. | Typ. | Max. | | |
| Supply voltage | ± 2.4 | | ± 5.5 | V | Bipolar supply, Gnd=0V @1kHz Sensor to skin Set by internal DC signal rejection network – coupling capacitor |
| Supply current | 0.6 | 2.5 | 3.5 | mA | |
| Effective input resistance | | 20 | | G Ω | |
| Effective input capacitance | | 15 | | pF | |
| Voltage Gain (A_v) | 47.5 | 50 | 52.5 | | |
| Coupling capacitance | | 250 | | pF | |
| Lower -3dB point | | 0.20 | | Hz | |
| Upper -3dB point | 4.0 | | | kHz | |

PIN ASSIGNMENT

Fig. 4 Pin Assignment for the PS25201B

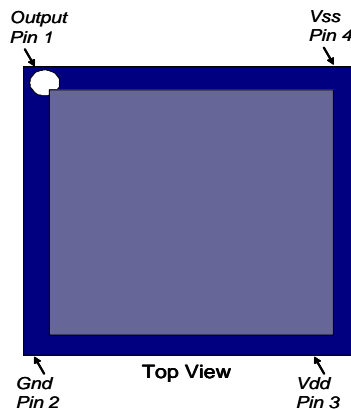

MECHANICAL DIMENSIONS

The package diagram is shown below. It is recommended that a solder pad 1.6mm diameter be defined for the mounting of the sensor pins.

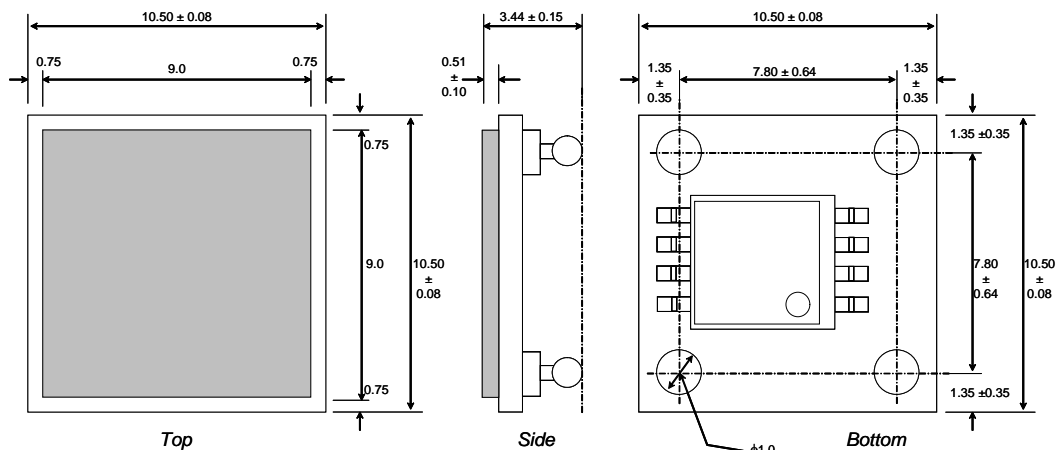

Mechanical Drawing (all dimensions are nominal and in mm)

ELECTROSTATIC DISCHARGE (ESD) PROTECTION

The PS25201B is manufactured using a high performance analog CMOS process. As for all CMOS components, it is essential that conventional ESD protection protocols be applied for the handling of this device.

APPLICATION OF THE ECG SENSOR

Because of the large coupling capacitance to the body (around 250pF) the EPIC sensor's internal electrometer can be used in differential mode to recover true surface potential ECG signals from the surface of the skin. A typical ECG signal at the surface of the skin is 1mV p-p.

Differential measurement of body (skin) surface potential to produce ECG trace

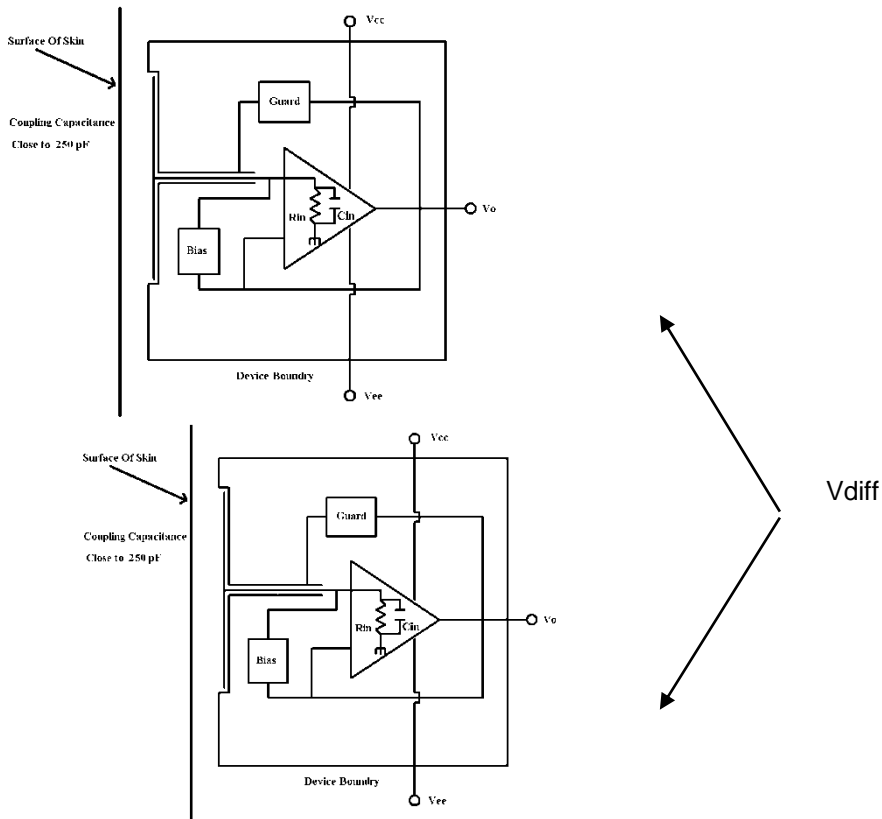

Fig. 8 Comparison of two vectors from a pair of EPIC sensors (top) and two conventional Ag/AgCl electrodes (bottom)



EPIC Ultra High Impedance ECG Sensor Advance Info PS25202

FEATURES

- Ultra high input resistance, typically 20G Ω .
- Dry-contact capacitive coupling.
- Input capacitance as low as 15pF.
- Lower -3dB point typically 50mHz to meet clinical ECG requirements.
- Upper -3dB point typically 10kHz.
- Operates with bipolar power supply from $\pm 2.4V$ to $\pm 4.0V$.
- Sensors supplied in a custom package with exposed pins for surface mount assembly.

APPLICATIONS

- Contact ECG signal detection for:
 - Non-critical patient monitoring equipment.
 - Emergency response diagnostics.
 - Lifestyle sports and health products.
 - Suitable for long-term and remote

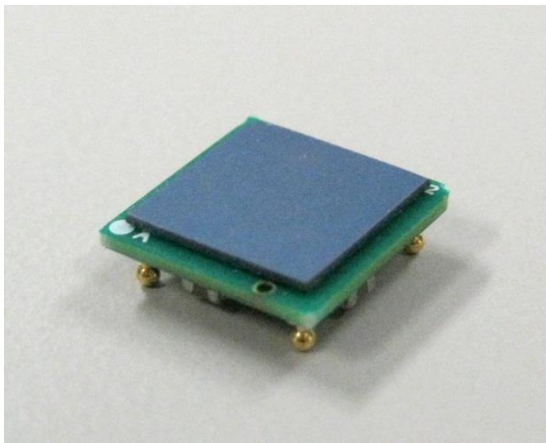

Fig. 1 PS25202



Plessey Semiconductors Electric Potential Integrated Circuit (EPIC) product line targets a range of applications.

The PS25202 is an ultra high impedance solid state ECG (electrocardiograph) sensor. It can be used as a dry contact ECG sensor without the need for potentially dangerous low impedance circuits across the heart. The resolution available is as good as or better than conventional wet electrodes.

The device uses active feedback techniques to both lower the effective input capacitance of the sensing element (C_{in}) and boost the input resistance (R_{in}). These techniques are used to realise a sensor with a frequency response suitable for both diagnostic and monitoring ECG applications.

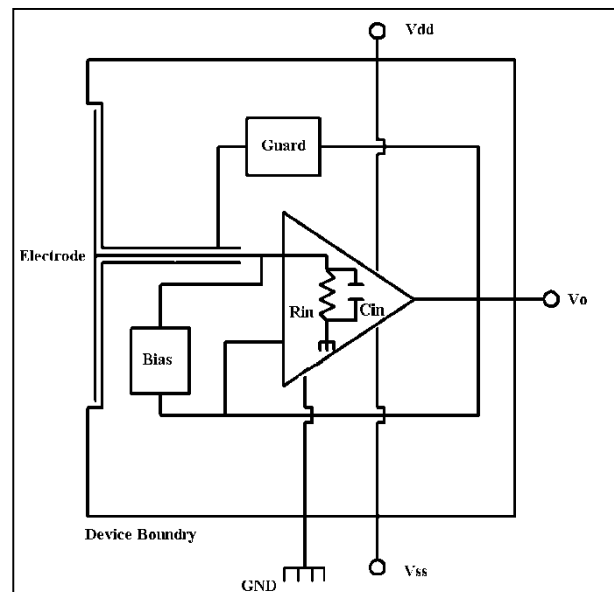
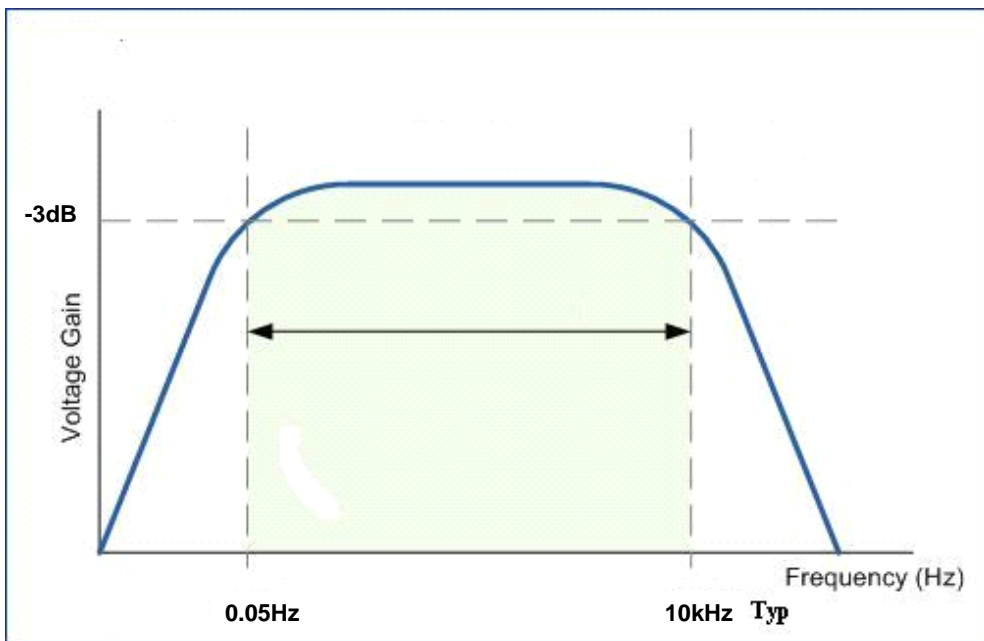

Fig. 2 Internal circuit of EPIC ECG Sensor

ELECTRICAL CHARACTERISTICS

$T_{amb} = -25^{\circ}\text{C}$ to $+75^{\circ}\text{C}$, $V_{dd}/V_{ss} \pm 2.4\text{V}$ to $\pm 4.0\text{V}$. The electrical characteristics are guaranteed by either production test or by design and characterisation. They apply within the specified ambient temperature and supply voltage unless otherwise stated.

| Characteristics | Value | | | Units | Conditions |
|-----------------------------|-----------|------|-----------|------------------|--|
| | Min. | Typ. | Max. | | |
| Supply voltage | ± 2.4 | | ± 4.0 | V | Bipolar supply, Gnd=0V |
| Supply current | 1.5 | 2.5 | 3.5 | mA | |
| Effective input resistance | | 20 | | $\text{G}\Omega$ | |
| Effective input capacitance | | 15 | | pF | |
| Voltage Gain (A_v) | | 50 | | | Sensor to skin Set by internal DC signal rejection network – coupling capacitor |
| Coupling capacitance | | 250 | | pF | |
| Lower -3dB point | | 0.05 | | Hz | |
| Upper -3dB point | | 10.0 | | kHz | |
| Noise | | tbd | | | |



Typical Bode Plot for EPIC ECG Sensor

PIN

ASSIGNM

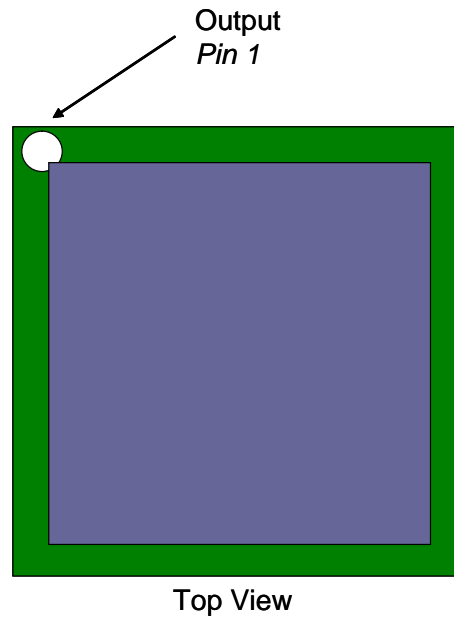
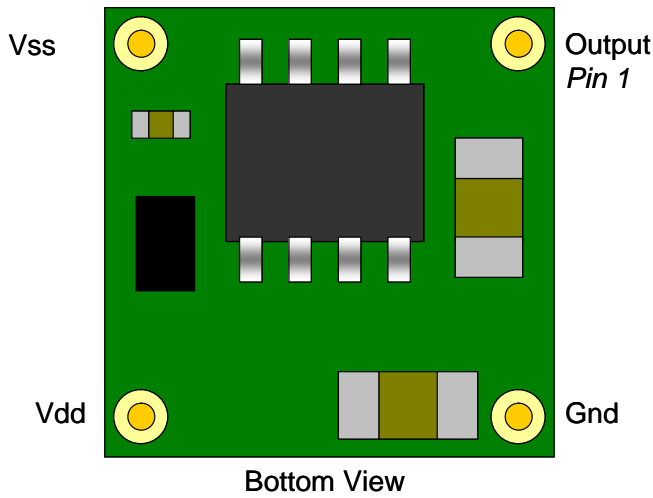

Pin Assignment for the PS25202

MECHANICAL DIMENSIONS

A preliminary package diagram is shown below. This is certain to change and so should only be used for illustration purposes.

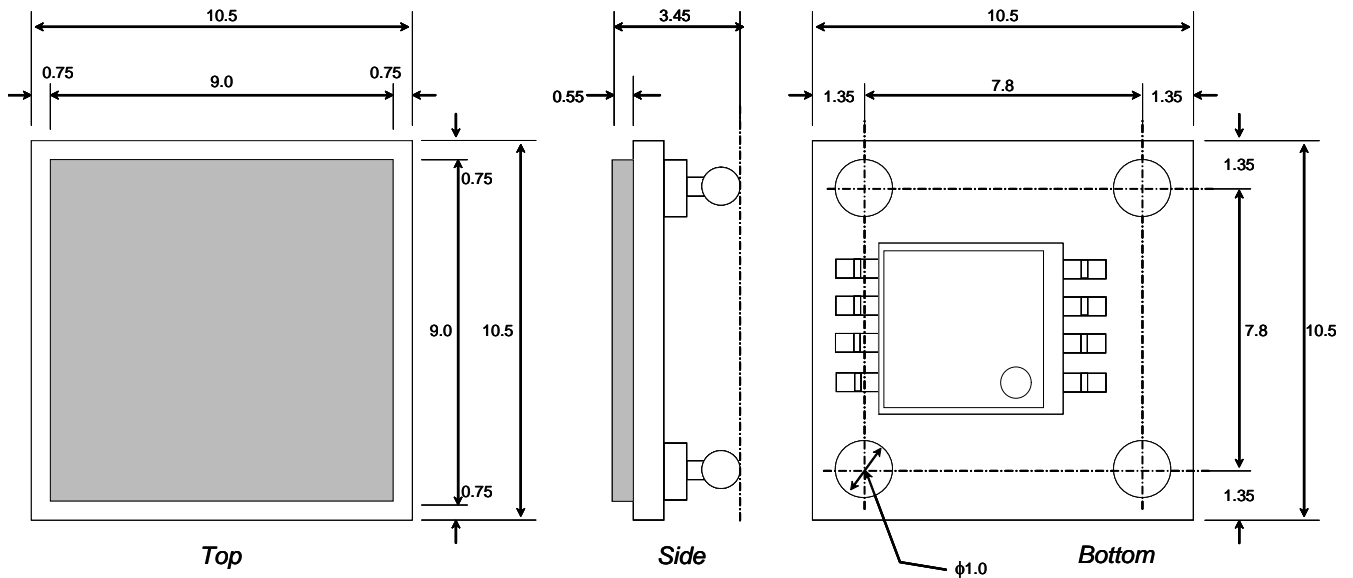

Fig. 5 Mechanical Drawing (all dimensions are nominal and in mm)

ELECTROSTATIC DISCHARGE (ESD) PROTECTION

The PS25202 is manufactured using a high performance analog CMOS process. As for all CMOS components, it is essential that conventional ESD protection protocols be applied for the handling of this device.

4.2.10 EPIC Ultra High Impedance Electrophysiological Sensor/ PS25203B

FEATURES

- Ultra high input resistance, typically 20G Ω .
- Dry-contact capacitive coupling.
- Input capacitance as low as 15pF.
- Lower -3dB point typically 200mHz.
- Upper -3dB point typically 20kHz.
- Operates with bipolar power supply from $\pm 2.4V$ to $\pm 4.0V$.
- Sensors supplied in a custom package with exposed pins for surface mount assembly.

APPLICATIONS

- Contact ECG signal detection for:
 - Non-critical patient monitoring equipment.
 - Emergency response diagnostics.
 - Lifestyle sports and health products.
 - Suitable for long-term and remote monitoring.

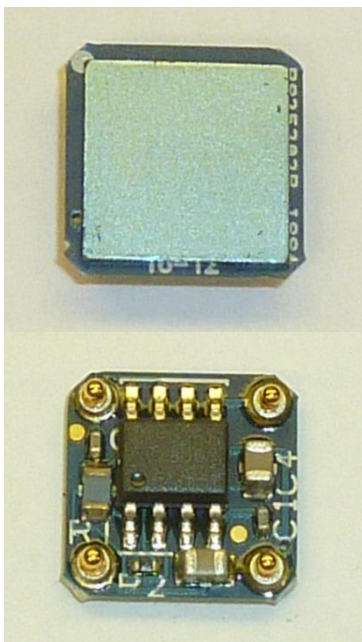

Fig. 1 PS25203B - Top and Bottom



Plessey Semiconductors Electric Potential Integrated Circuit (EPIC) product line targets a range of applications.

The PS25203B is an ultra-high impedance solid state ECG (electrocardiograph) sensor. It can be used as a dry contact ECG sensor without the need for potentially dangerous low impedance circuits across the heart. The resolution available is as good as or better than conventional wet electrodes.

The device uses active feedback techniques to both lower the effective input capacitance of the sensing element (C_{in}) and boost the input resistance (R_{in}). These techniques are used to realise a sensor with a frequency response suitable for both diagnostic and monitoring ECG applications.

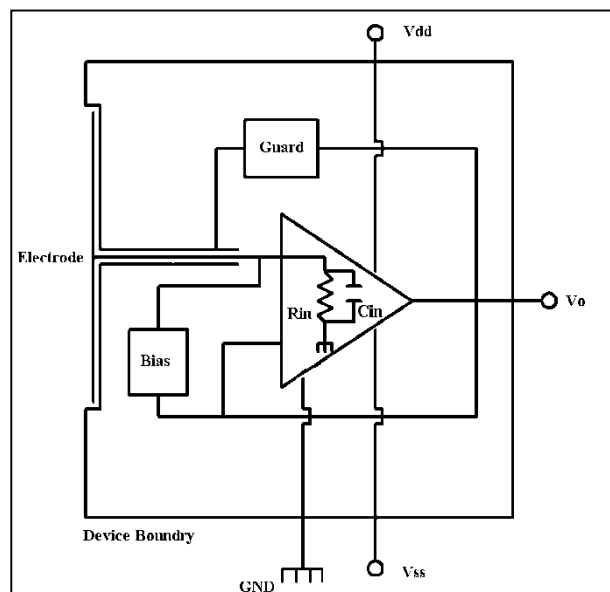
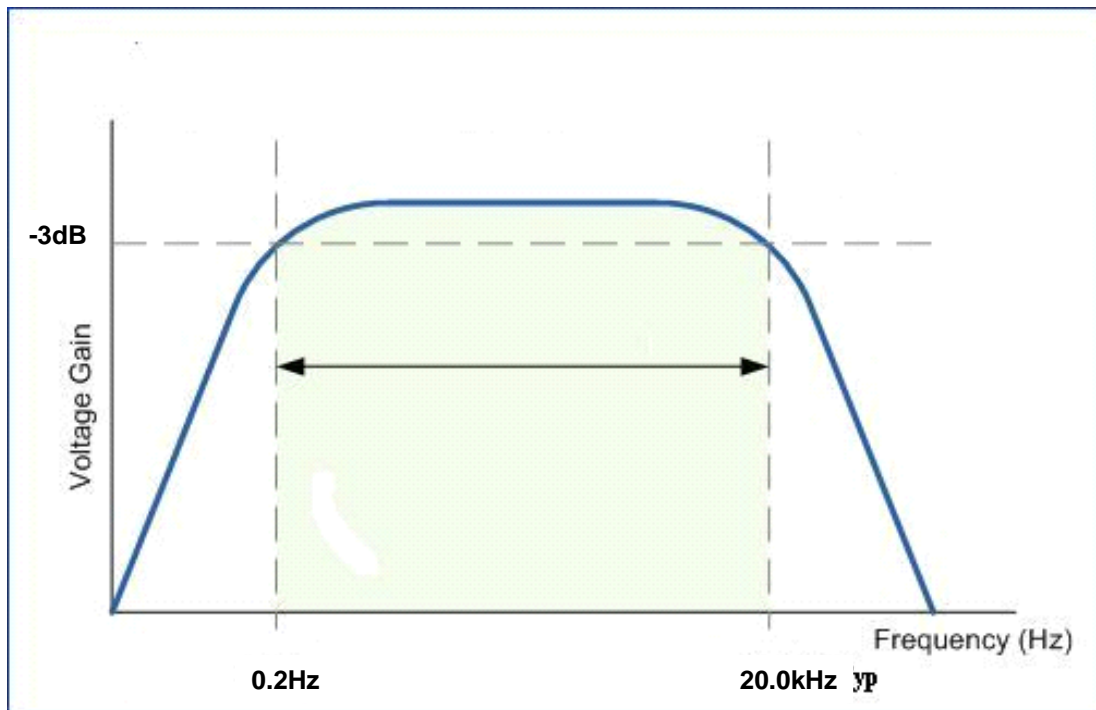

Fig. 2 Internal circuit of EPIC ECG Sensor

ELECTRICAL CHARACTERISTICS

$T_{amb} = -25^{\circ}\text{C}$ to $+75^{\circ}\text{C}$, $V_{dd}/V_{ss} \pm 2.4\text{V}$ to $\pm 4.0\text{V}$. The electrical characteristics are guaranteed by either production test or by design and characterisation. They apply within the specified ambient temperature and supply voltage unless otherwise stated.

| Characteristics | Value | | | Units | Conditions |
|-----------------------------|-----------|------|-----------|------------|--|
| | Min. | Typ. | Max. | | |
| Supply voltage | ± 2.4 | | ± 4.0 | V | Bipolar supply, Gnd=0V Sensor to skin Set by internal DC signal rejection network – coupling |
| Supply current | 1.5 | 2.5 | 3.5 | mA | |
| Effective input resistance | | 20 | | G Ω | |
| Effective input capacitance | | 15 | | pF | |
| Voltage Gain (A_v) | | 10 | | | |
| Coupling capacitance | | 250 | | pF | |
| Lower -3dB point | | 0.20 | | Hz | |
| Upper -3dB point | | 20.0 | | kHz | |
| Noise | | tbd | | | |



Typical Bode Plot for EPIC ECG Sensor

PIN ASSIGNMENT

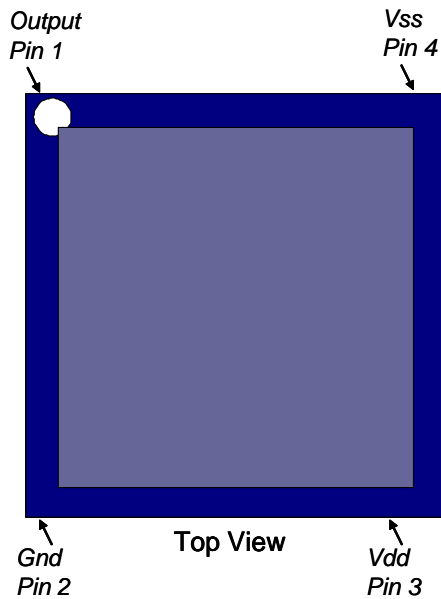

Pin Assignment for the PS25203B

MECHANICAL DIMENSIONS

The package diagram is shown below. It is recommended that a solder pad 1.6mm diameter be defined for the mounting of the sensor pins.

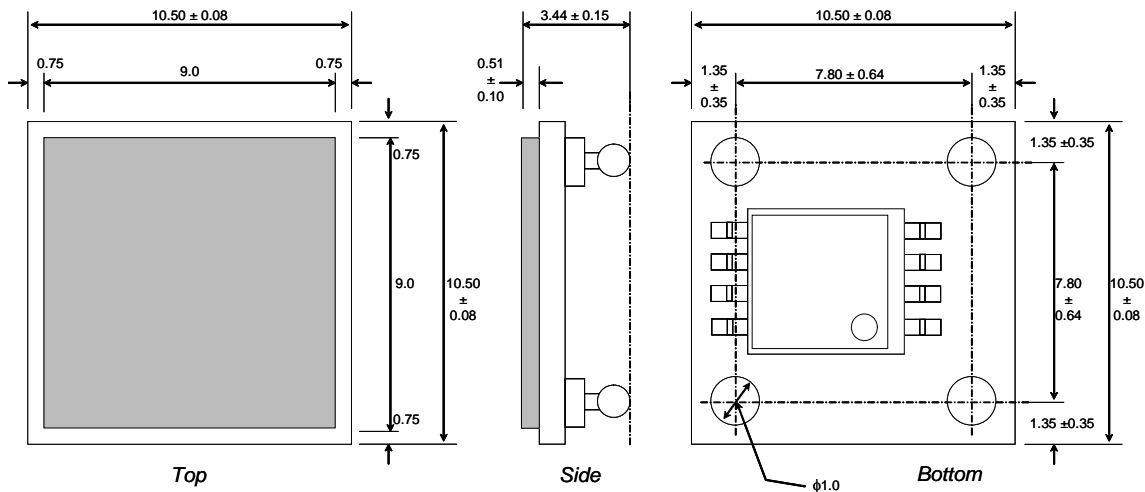

Mechanical Drawing (all dimensions are nominal and in mm)

ELECTROSTATIC DISCHARGE (ESD) PROTECTION

The PS25203B is manufactured using a high performance analog CMOS process. As for all CMOS components, it is essential that conventional ESD protection protocols be applied for the handling of this device.

APPLICATION OF THE ECG SENSOR

Because of the large coupling capacitance to the body (around 250pF) the EPIC sensor's internal electrometer can be used in differential mode to recover true surface potential ECG signals from the surface of the skin. A typical ECG signal at the surface of the skin is 1mV p-p.

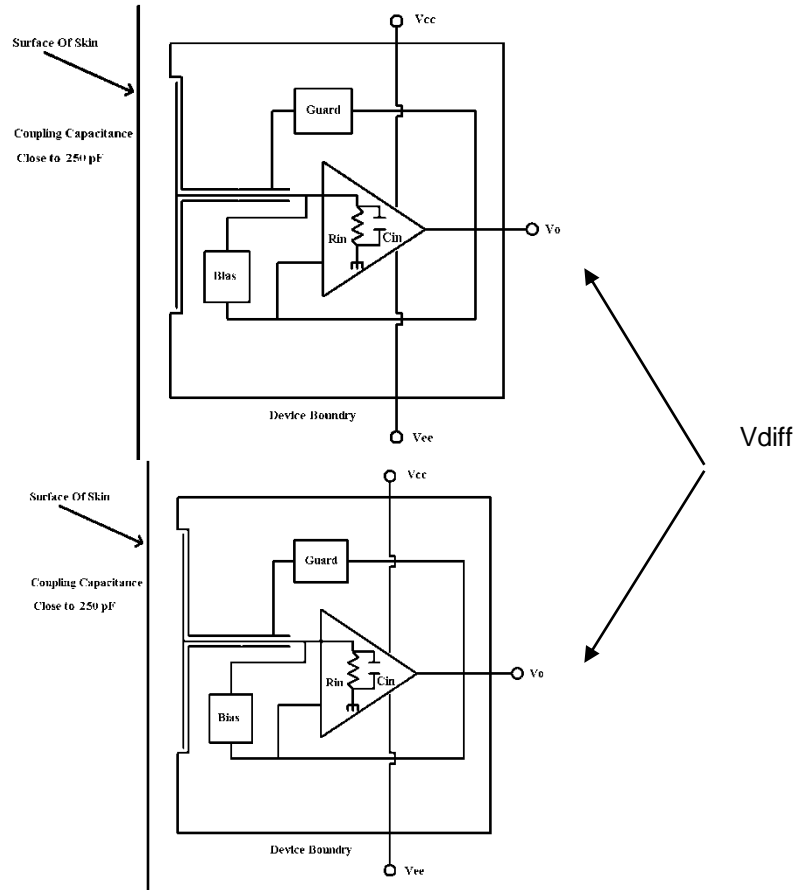

Fig. 7 Differential measurement of body (skin) surface potential to produce ECG trace



Fig. 8 Comparison of two vectors from a pair of EPIC sensors (top) and two conventional Ag/AgCl electrodes (bottom)

4.2.11 EPIC Ultra High Impedance ECG Sensor Advance Info PS25204

FEATURES

- Ultra high input resistance, typically 20G Ω .
- Dry-contact capacitive coupling.
- Input capacitance as low as 15pF.
- Lower -3dB point typically 50mHz to meet clinical ECG requirements.
- Upper -3dB point typically 20kHz.
- Operates with bipolar power supply from $\pm 2.4V$ to $\pm 4.0V$.
- Sensors supplied in a custom package with exposed pins for surface mount assembly.

APPLICATIONS

- Contact ECG signal detection for:
 - Non-critical patient monitoring equipment.
 - Emergency response diagnostics.
 - Lifestyle sports and health products.
 - Suitable for long-term and remote monitoring.

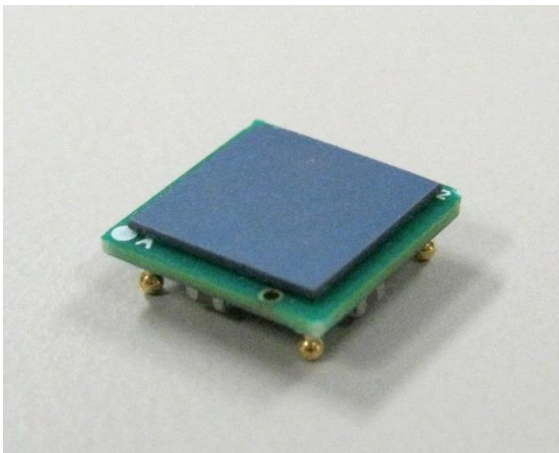

PS25204



Plessey Semiconductors Electric Potential Integrated Circuit (EPIC) product line targets a range of applications.

The PS25204 is an ultra high impedance solid state ECG (electrocardiograph) sensor. It can be used as a dry contact ECG sensor without the need for potentially dangerous low impedance circuits across the heart. The resolution available is as good as or better than conventional wet electrodes.

The device uses active feedback techniques to both lower the effective input capacitance of the sensing element (C_{in}) and boost the input resistance (R_{in}). These techniques are used to realise a sensor with a frequency response suitable for both diagnostic and monitoring ECG applications.

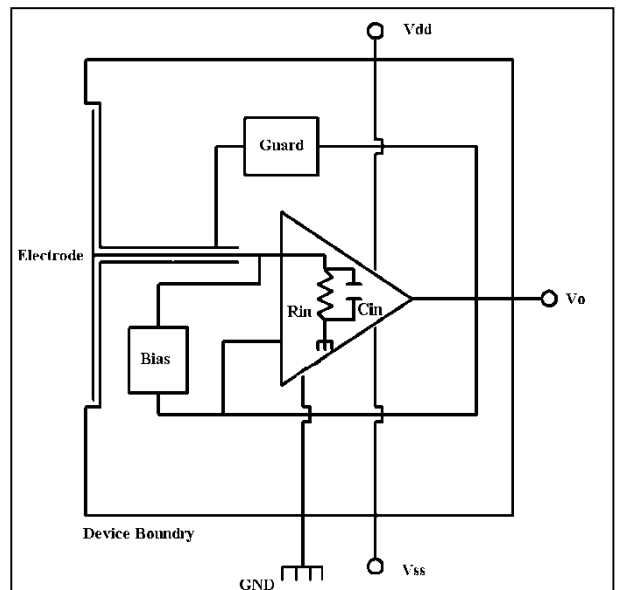

Internal circuit of EPIC ECG Sensor

ELECTRICAL CHARACTERISTICS

$T_{amb} = -25^{\circ}\text{C}$ to $+75^{\circ}\text{C}$, $V_{dd}/V_{ss} \pm 2.4\text{V}$ to $\pm 4.0\text{V}$. The electrical characteristics are guaranteed by either production test or by design and characterisation. They apply within the specified ambient temperature and supply voltage unless otherwise stated.

| Characteristics | Value | | | Units | Conditions |
|-----------------------------|-----------|------|-----------|------------|--|
| | Min. | Typ. | Max. | | |
| Supply voltage | ± 2.4 | | ± 4.0 | V | Bipolar supply, Gnd=0V Sensor to skin Set by internal DC signal rejection network – coupling capacitor |
| Supply current | 1.5 | 2.5 | 3.5 | mA | |
| Effective input resistance | | 20 | | G Ω | |
| Effective input capacitance | | 15 | | pF | |
| Voltage Gain (A_v) | | 10 | | | |
| Coupling capacitance | | 250 | | pF | |
| Lower -3dB point | | 0.05 | | Hz | |
| Upper -3dB point | | | | kHz | |
| Noise | | tbd | | | |

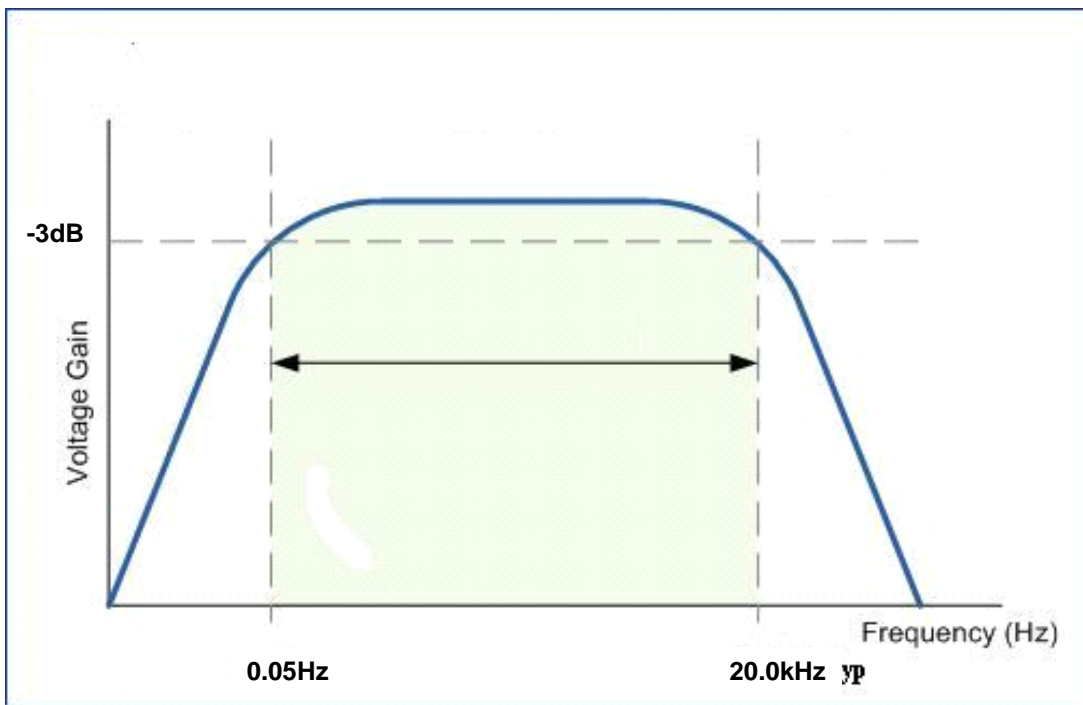
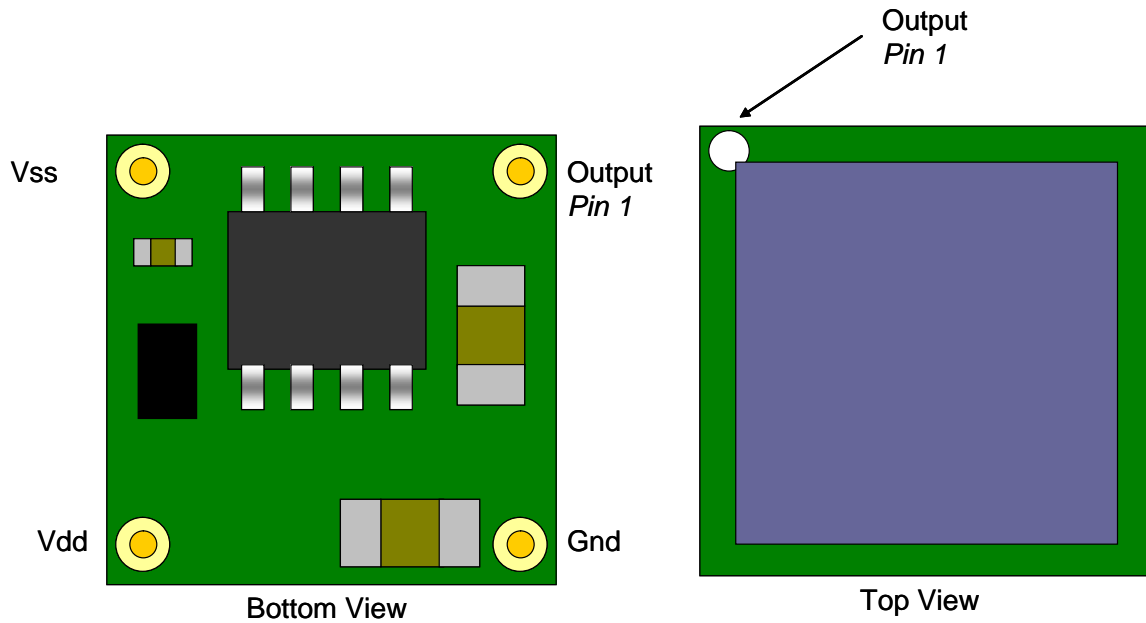

Fig. 3 Typical Bode Plot for EPIC ECG Sensor

PIN ASSIGNMENT



Pin Assignment for the PS25204

MECHANICAL DIMENSIONS

A preliminary package diagram is shown below. This is certain to change and so should only be used for illustration purpose

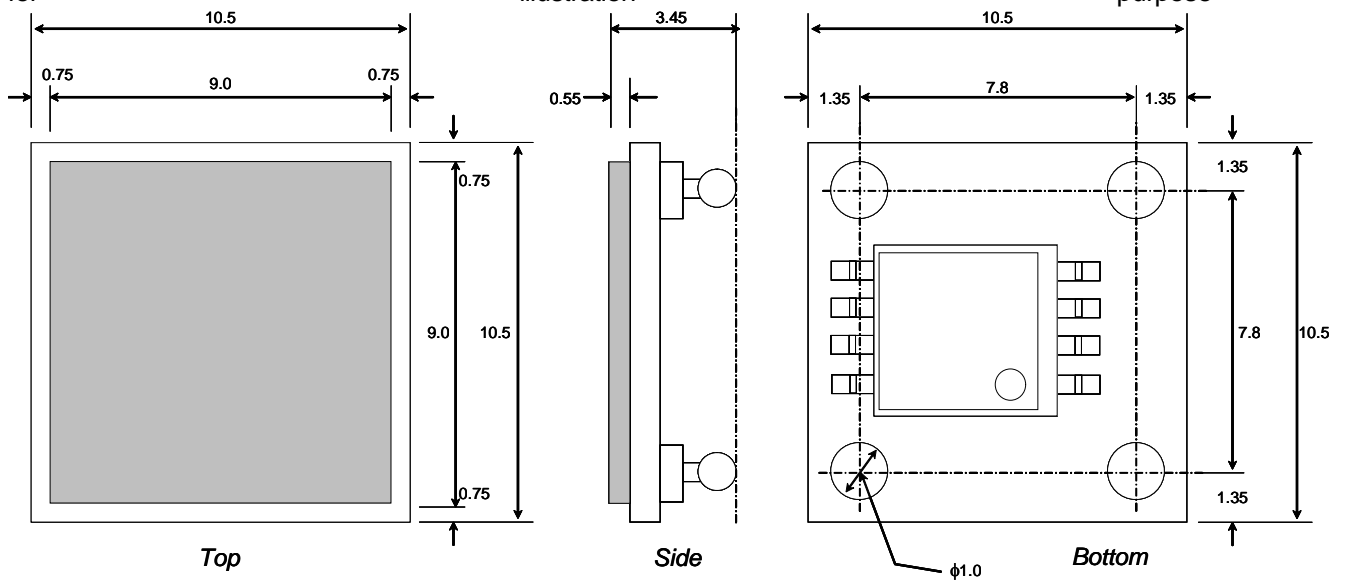

Fig. 5 Mechanical Drawing (all dimensions are nominal and in mm)

ELECTROSTATIC DISCHARGE (ESD) PROTECTION

The PS25204 is manufactured using a high performance analog CMOS process. As for all CMOS components, it is essential that conventional ESD protection protocols be applied for the handling of this device.

APPLICATION OF THE ECG SENSOR

Because of the large coupling capacitance to the body (around 250pF) the EPIC sensor's internal electrometer can be used in differential mode to recover true surface potential ECG signals from the surface of the skin. A typical ECG signal at the surface of the skin is 1mV p-p.

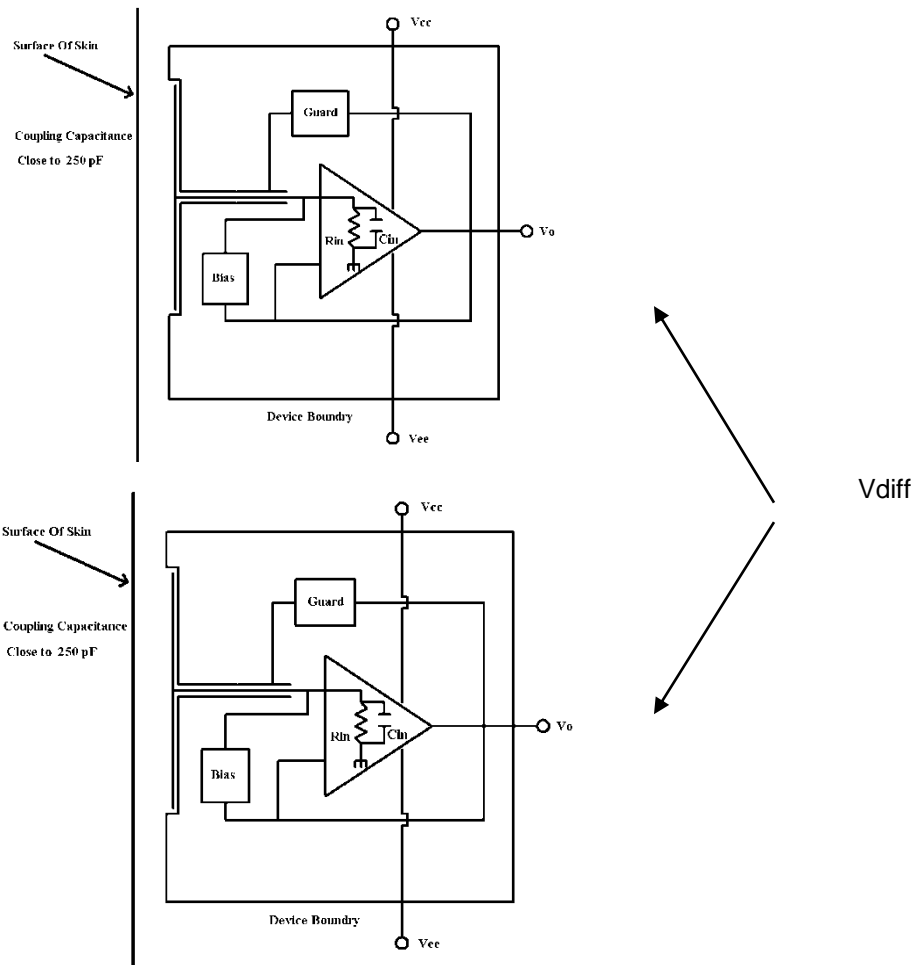

Differential measurement of body (skin) surface potential to produce ECG trace



Comparison of two vectors from a pair of EPIC sensors (top) and two conventional Ag/AgCl electrodes (bottom)

4.2.12 EPIC Ultra High Impedance ECG Sensor Advance Info PS25251

FEATURES

- Ultra high input resistance, typically 20G Ω .
- Dry-contact capacitive coupling.
- Input capacitance as low as 15pF.
- Lower -3dB point typically 200mHz.
- Upper -3dB point typically 10kHz.
- Operates with bipolar power supply from $\pm 2.4V$ to $\pm 5.5V$.
- Sensors supplied in a custom package with exposed pins for surface mount assembly.

APPLICATIONS

- Contact ECG signal detection for:
 - Non-critical patient monitoring equipment.
 - Emergency response diagnostics.
 - Lifestyle sports and health products.
 - Suitable for long-term and remote monitoring.

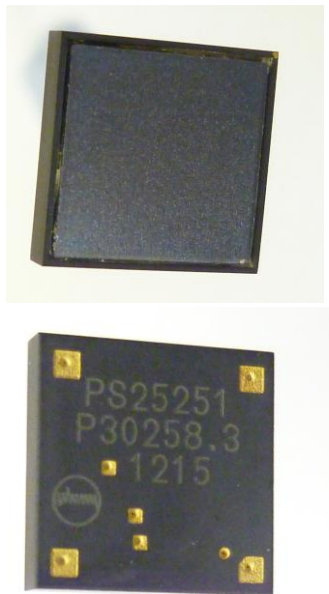

Fig. 1 PS25251 (top and bottom)



Plessey Semiconductors Electric Potential Integrated Circuit (EPIC) product line targets a range of applications.

The PS25251 is an ultra high impedance solid state ECG (electrocardiograph) sensor. It can be used as a dry contact ECG sensor without the need for potentially dangerous low impedance circuits across the heart. The resolution available is as good as or better than conventional wet electrodes.

The device uses active feedback techniques to both lower the effective input capacitance of the sensing element (C_{in}) and boost the input resistance (R_{in}). These techniques are used to realise a sensor with a frequency response suitable for both diagnostic and monitoring ECG applications.

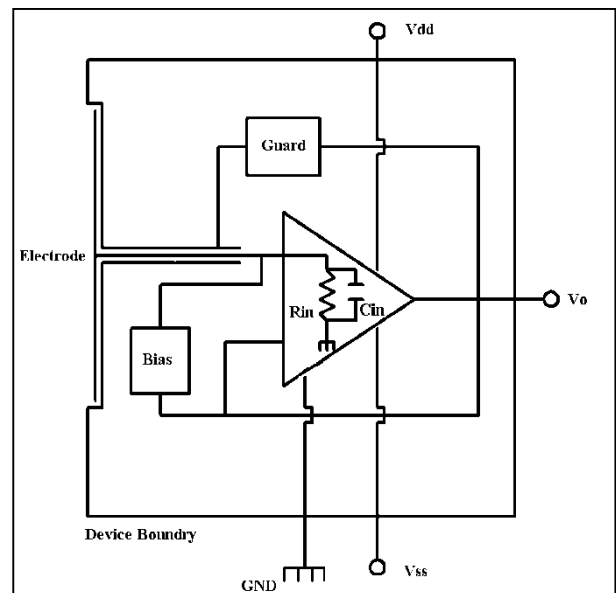

Fig. 2 Internal circuit of EPIC ECG Sensor

ELECTRICAL CHARACTERISTICS

$T_{amb} = -25^{\circ}\text{C}$ to $+75^{\circ}\text{C}$, $V_{dd}/V_{ss} \pm 2.4\text{V}$ to $\pm 5.5\text{V}$. The electrical characteristics are guaranteed by either production test or by design and characterisation. They apply within the specified ambient temperature and supply voltage unless otherwise stated.

| Characteristics | Value | | | Units | Conditions |
|---------------------------------------|-----------|------|-----------|------------|--|
| | Min. | Typ. | Max. | | |
| Supply voltage | ± 2.4 | | ± 5.5 | V | Bipolar supply, Gnd=0V |
| Supply current | 0.6 | 2.0 | 3.5 | mA | |
| Effective input resistance | | 20 | | G Ω | |
| Effective input capacitance | | 15 | | pF | |
| Primary Output Voltage Gain (A_v) | 47.5 | 50 | 52.5 | | @1kHz |
| Coupling capacitance | | 250 | | pF | Sensor to skin |
| Guard Output voltage gain | 0.95 | 1.0 | 1.05 | | @1kHz |
| Lower -3dB point | | 0.20 | | Hz | Set by internal DC signal rejection network – coupling capacitor |
| Upper -3dB point | 4.0 | | | kHz | |

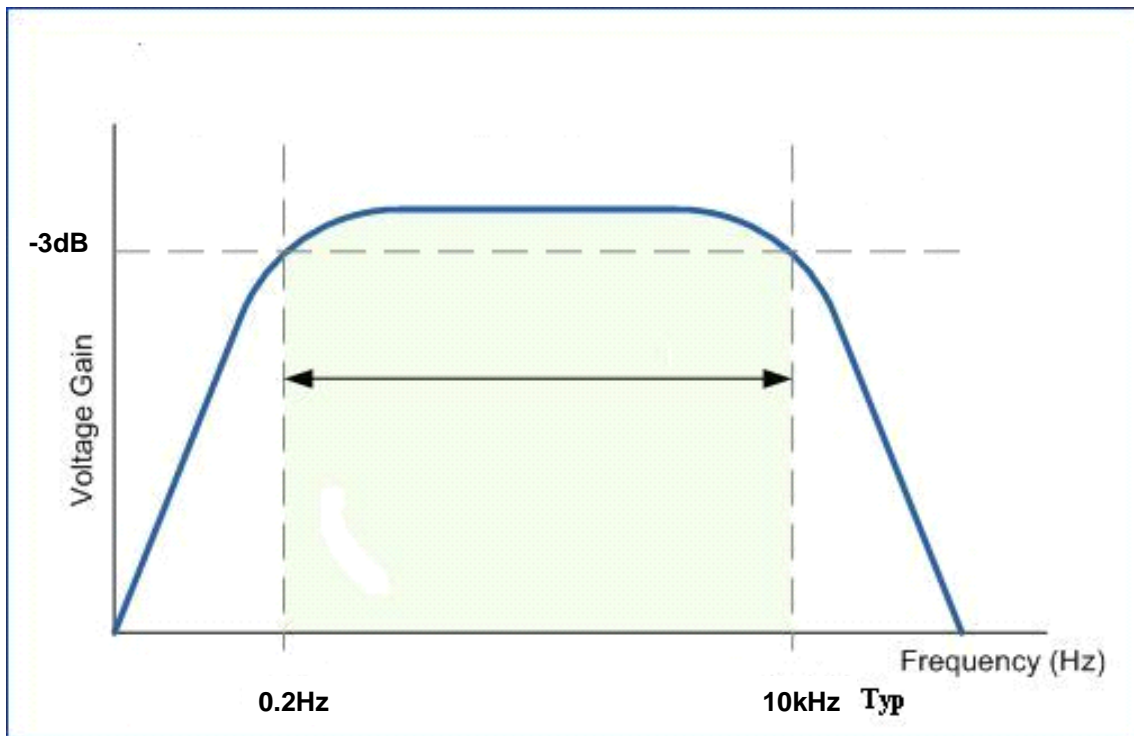

Fig. 3 Typical Bode Plot for EPIC ECG Sensor

PIN ASSIGNMENT

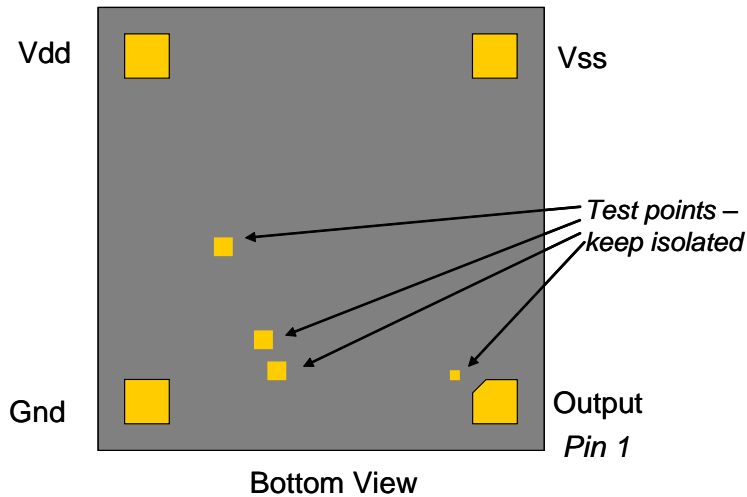

Fig. 4 Pin Assignment for the PS25251

MECHANICAL DIMENSIONS

A preliminary package diagram is shown below. This is certain to change and so should only be used for illustration purposes.

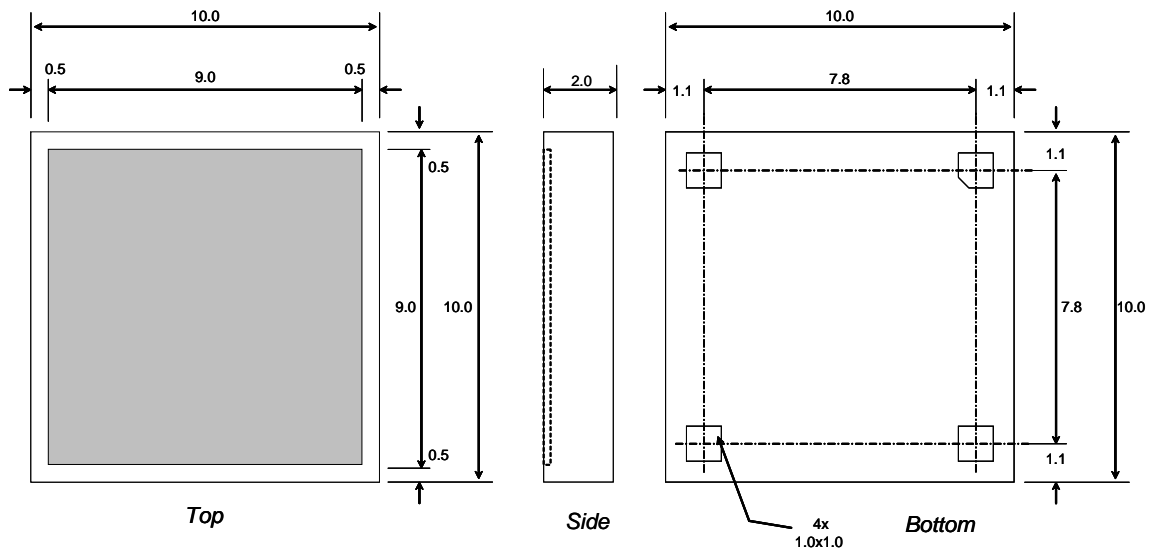

Fig. 5 Mechanical Drawing (all dimensions are nominal and in mm)

ELECTROSTATIC DISCHARGE (ESD) PROTECTION

The PS25251 is manufactured using a high performance analog CMOS process. As for all CMOS components, it is essential that conventional ESD protection protocols be applied for the handling of this device.

APPLICATION OF THE ECG SENSOR

Because of the large coupling capacitance to the body (around 250pF) the EPIC sensor's internal electrometer can be used in differential mode to recover true surface potential ECG signals from the surface of the skin. A typical ECG signal at the surface of the skin is 1mV p-p.

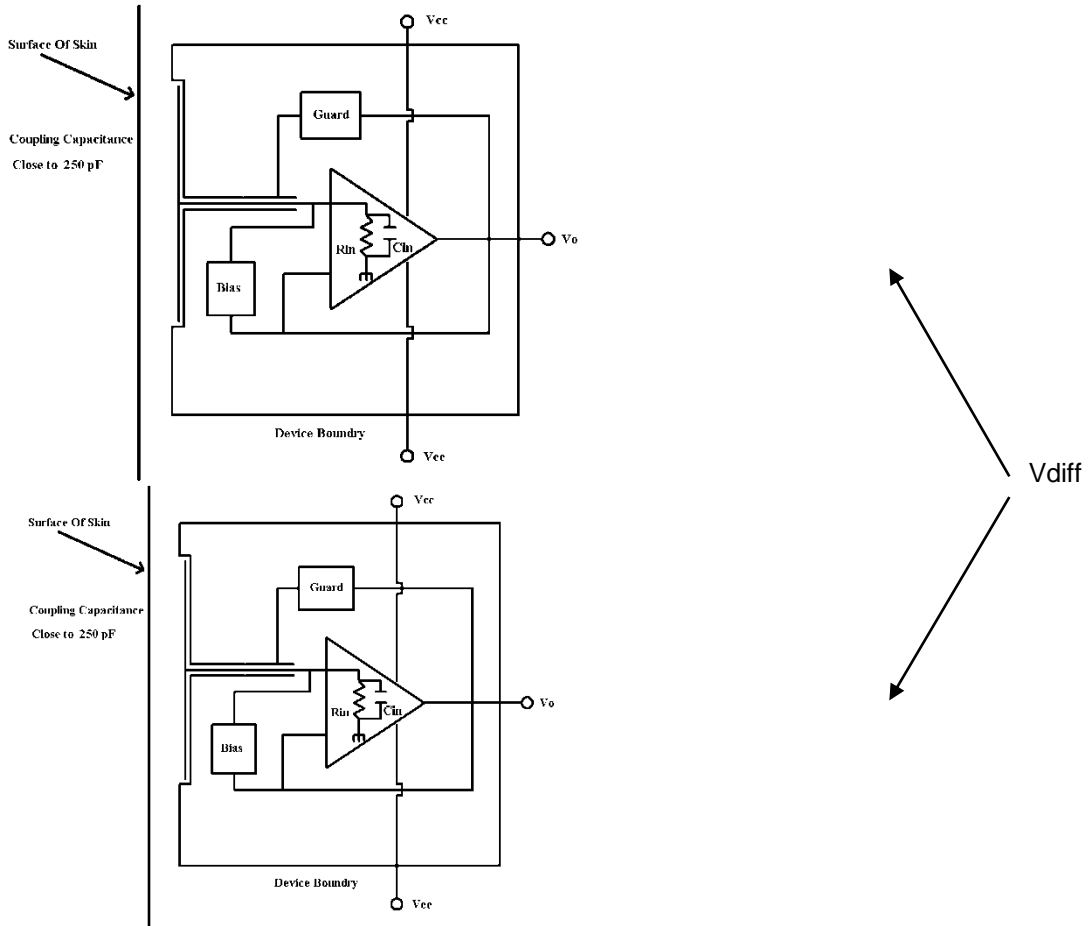

Fig. 7 Differential measurement of body (skin) surface potential to produce ECG trace



Fig. 8 Comparison of two vectors from a pair of EPIC sensors (top) and two conventional Ag/AgCl electrodes (bottom)

4.2.13 EPIC Ultra High Impedance Movement Sensor/ PS25401A/B

FEATURES

- Ultra high effective input resistance, typically 20G Ω .
- Effective input capacitance as low as 15pF.
- Upper 3dB point typically 10kHz.
- Operates with bipolar power supply from $\pm 2.4V$ to $\pm 4.0V$.
- Sensors supplied in a custom package with exposed pins for surface mount assembly.

APPLICATIONS

- Proximity switching of lighting and similar electric circuits
- Remote control of TVs and other domestic appliances
- Presence detection for security / alarm systems
- Room occupancy detection for rescue services
- Simple gesture recognition to control children's toys
- Controller-less computer gaming systems

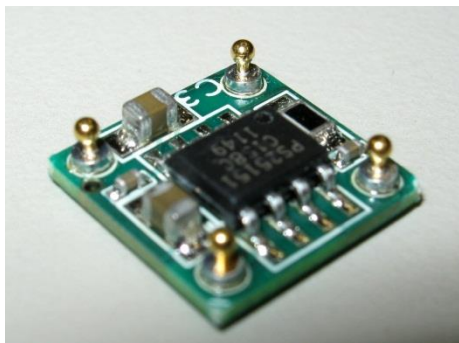
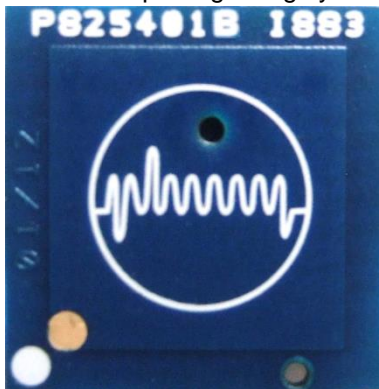

Fig. 1 The PS25401B Sensor



Plessey Semiconductors Electric Potential Integrated Circuit (EPIC) product line targets a range of applications.

The PS25401B is an ultra high impedance non-contact solid state electric potential sensor. It can be used to detect field disturbance due to the movement of a near-by object. This functionality can be employed in a range of applications including security motion sensors and non-contact electric switches for lighting, door opening, toys etc

The device uses active feedback techniques to both lower the effective input capacitance of the sensing element (C_{in}) and boost the input resistance (R_{in}). These techniques are used to realise a sensor with a frequency response suitable for remote sensing applications.

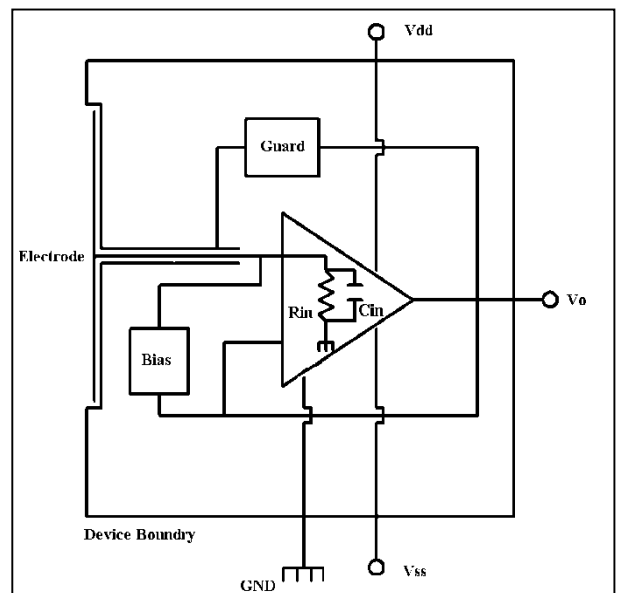

Fig. 2 Internal circuit of EPIC Movement Sensor

ELECTRICAL CHARACTERISTICS

$T_{amb} = -25^{\circ}\text{C}$ to $+75^{\circ}\text{C}$, $V_{dd}/V_{ss} \pm 2.4\text{V}$ to $\pm 4.0\text{V}$. The electrical characteristics are guaranteed by either production test or by design and characterisation. They apply within the specified ambient temperature and supply voltage unless otherwise stated.

| Characteristics | Value | | | Units | Conditions |
|-----------------------------|-----------|------|-----------|------------|--|
| | Min. | Typ. | Max. | | |
| Supply voltage | ± 2.4 | | ± 4.0 | V | Bipolar supply, Gnd=0V |
| Supply current | 1.5 | 2.5 | 3.5 | mA | |
| Effective input resistance | | 20 | | G Ω | |
| Effective input capacitance | | 15 | | pF | As measured at the sensor electrode |
| Voltage Gain (A_v) | | 50 | | | When measured with 250pF coupling capacitance |
| Lower -3dB point | | 0.20 | | Hz | Set by internal DC signal rejection network – coupling capacitor 250pF |
| Upper -3dB point | | 10.0 | | kHz | |
| Noise | | tbd | | | |

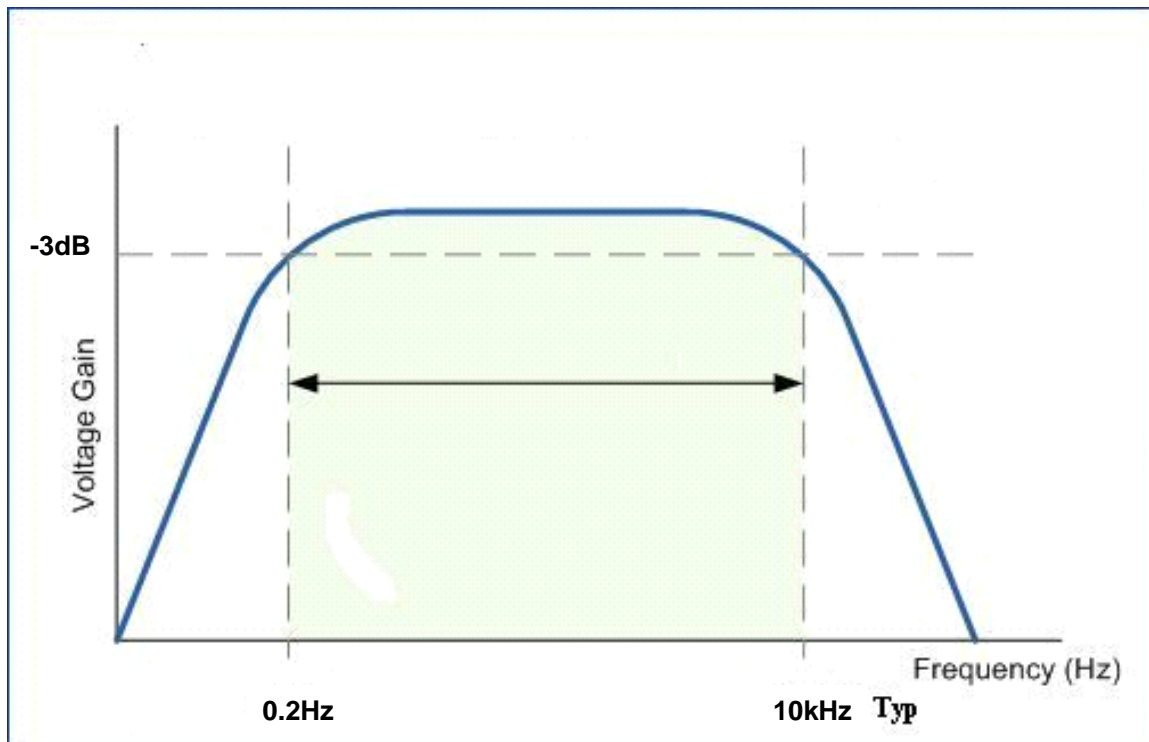
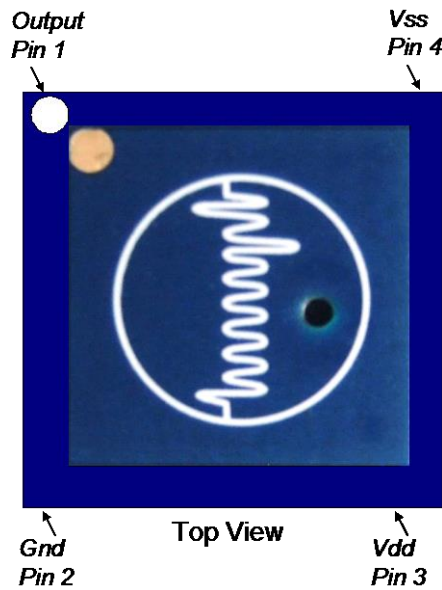

Fig. 3 Typical Bode Plot for PS25401B Sensor with Coupling through 250pF Capacitor

PIN ASSIGNMENT



Pin Assignment for the PS25401B – Top View

MECHANICAL DIMENSIONS

The package diagram is shown below. It is recommended that a solder pad 1.6mm diameter be defined for the mounting of the sensor pins.

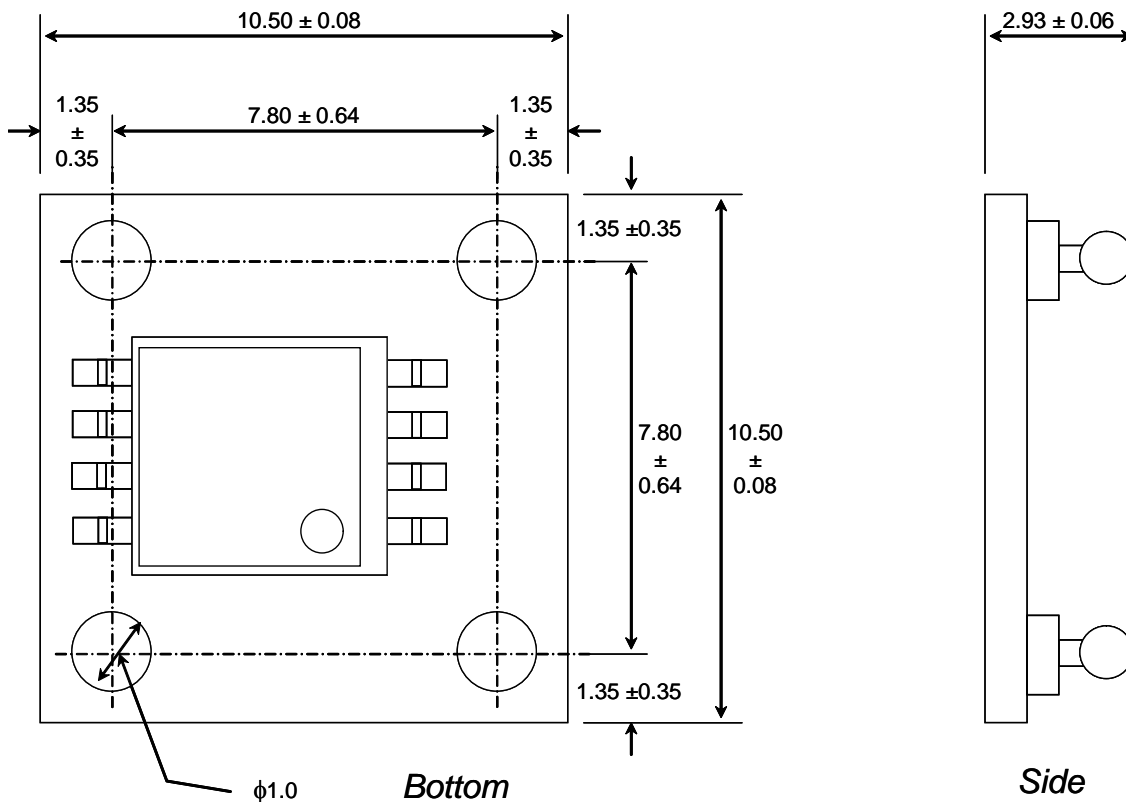

Mechanical Drawing (all dimensions are nominal and in mm)

ELECTROSTATIC DISCHARGE (ESD) PROTECTION

The PS25401B is manufactured using a high performance analog CMOS process. As for all CMOS components, it is essential that conventional ESD protection protocols be applied for the handling of this device.

4.2.14 EPIC Ultra High Impedance Movement Sensor Advance Information

FEATURES

- Ultra high input resistance, typically $> 300\text{G}\Omega$.
- Input capacitance as low as 16pF .
- Upper 3dB point typically 20kHz .
- Operates with bipolar power supply from $\pm 2.4\text{V}$ to $\pm 4.0\text{V}$.
- Sensors supplied in a custom package with exposed pins for surface mount assembly.

APPLICATIONS

- Proximity switching of lighting and similar electric circuits
- Remote control of TVs and other domestic appliances
- Presence detection for security / alarm systems
- Room occupancy detection for rescue services
- Simple gesture recognition to control children's toys
- Controller-less computer gaming systems
- Remote life-sign detection

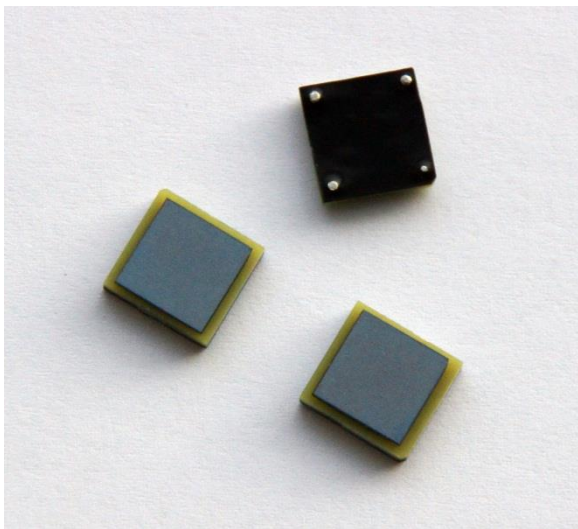
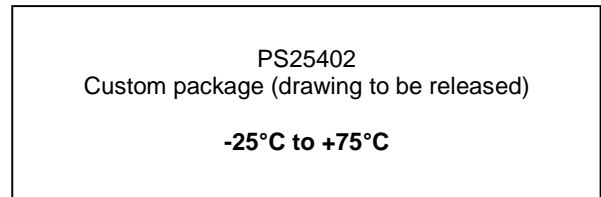

Fig. 1 The PS25402 Sensor



Plessey Semiconductors Electric Potential Integrated Circuit (EPIC) product line targets a range of applications.

The PS25402 is an ultra high impedance non-contact solid state electric potential sensor. It can be used to detect field disturbance due to the movement of a near-by object. This particular sensor has been optimised for movement and remote life-sign detection.

The device uses active feedback techniques to both lower the effective input capacitance of the sensing element (C_{in}) and boost the input resistance (R_{in}). These techniques are used to realise a sensor with a frequency response suitable for remote sensing applications.

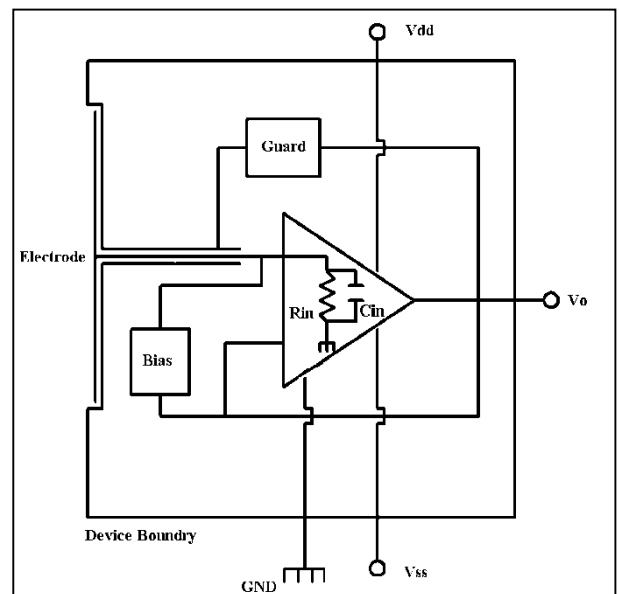

Fig. 2 Internal circuit of EPIC Movement Sensor

ELECTRICAL CHARACTERISTICS

$T_{amb} = -25^{\circ}\text{C}$ to $+75^{\circ}\text{C}$, $V_{dd}/V_{ss} \pm 2.4\text{V}$ to $\pm 4.0\text{V}$. The electrical characteristics are guaranteed by either production test or by design and characterisation. They apply within the specified ambient temperature and supply voltage unless otherwise stated.

| Characteristics | Value | | | Units | Conditions |
|------------------------------------|-----------|------|-----------|------------|-----------------|
| | Min. | Typ. | Max. | | |
| Supply voltage | ± 2.4 | | ± 4.0 | V | Bipolar, Gnd=0V |
| Supply current | 1.5 | 2.1 | 3.0 | mA | |
| Input resistance (Rin) | | 300 | tbd | G Ω | |
| Input capacitance | | 16 | | pF | |
| Voltage Gain (Av) | | 10 | | | |
| Effective input capacitance (Cine) | | 16 | | pF | |
| Noise | | tbd | | | |

PIN ASSIGNMENT

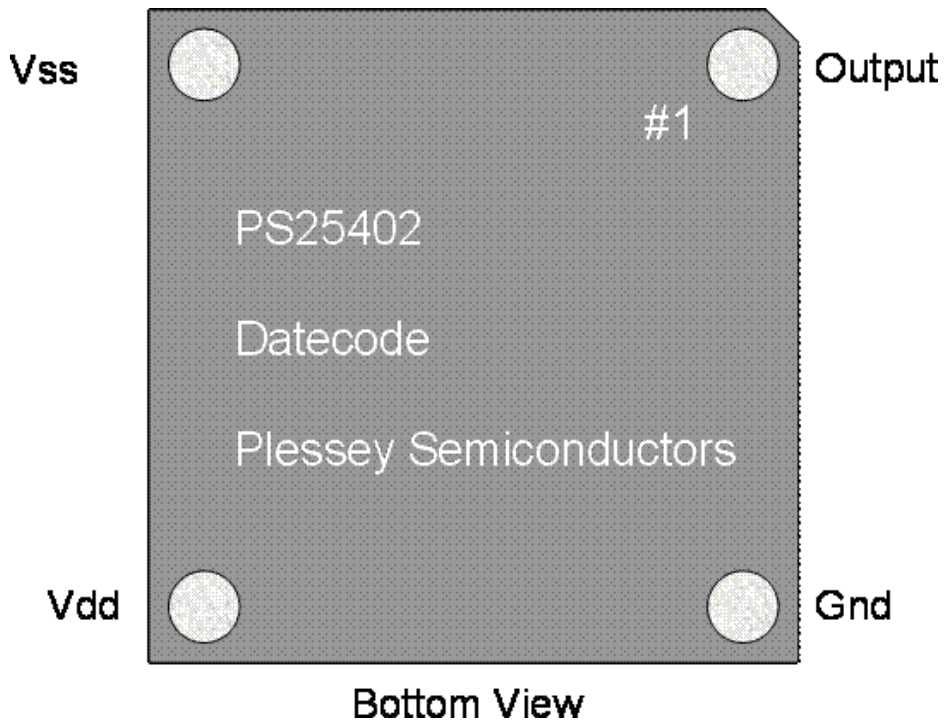

Fig. 3 Pin Assignment for the PS25402 – Bottom View

MECHANICAL DIMENSIONS

A preliminary package diagram is shown below. This is certain to change and so should only be used for illustration purposes.

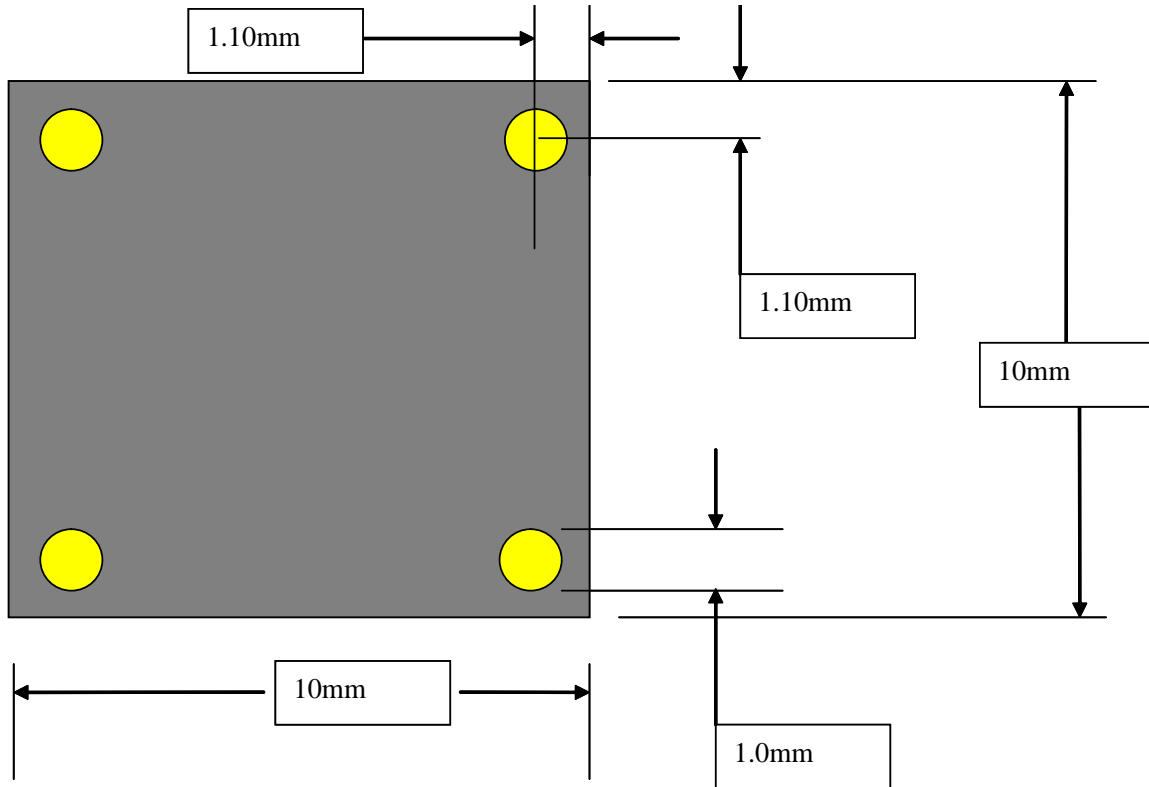
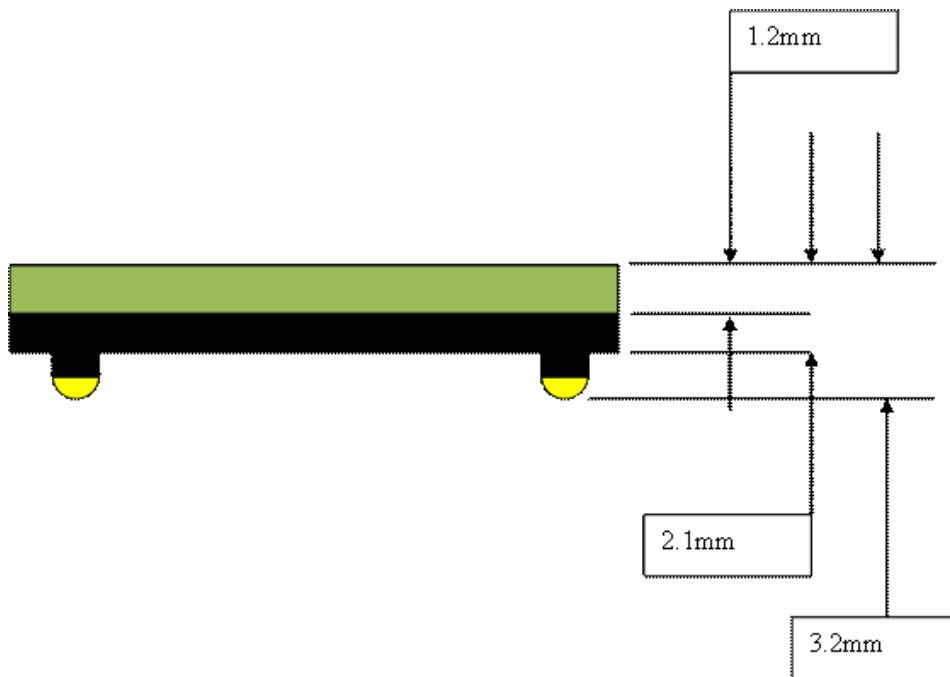

Fig. 4 Underside View of the Module



Side view of Module

4.2.15 EPIC Ultra High Impedance Movement Sensor/PS25451 Advance Info

FEATURES

- Ultra high effective input resistance, typically 20G Ω .
- Effective input capacitance as low as 15pF.
- Upper 3dB point typically 10kHz.
- Operates with bipolar power supply from $\pm 2.4V$ to $\pm 5.5V$.
- Sensors supplied in a custom package with exposed pins for surface mount assembly.

APPLICATIONS

- Proximity switching of lighting and similar electric circuits
- Remote control of TVs and other domestic appliances
- Presence detection for security / alarm systems
- Room occupancy detection for rescue services
- Simple gesture recognition to control children's toys
- Controller-less computer gaming systems

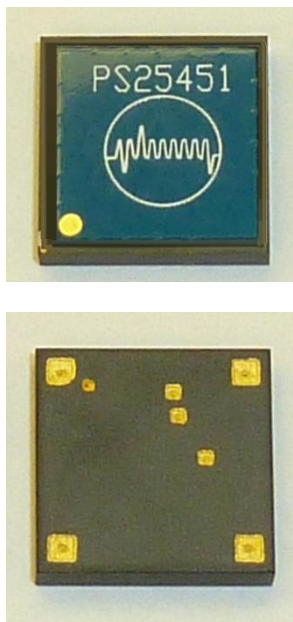
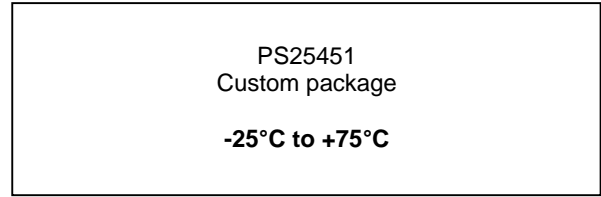

Fig. 1 The PS25451 Sensor Top and Bottom



Plessey Semiconductors Electric Potential Integrated Circuit (EPIC) product line targets a range of applications.

The PS25451 is an ultra-high impedance non-contact solid state electric potential sensor. It can be used to detect field disturbance due to the movement of a near-by object. This functionality can be employed in a range of applications including security motion sensors and non-contact electric switches for lighting, door opening, toys etc

The device uses active feedback techniques to both lower the effective input capacitance of the sensing element (C_{in}) and boost the input resistance (R_{in}). These techniques are used to realise a sensor with a frequency response suitable for remote sensing applications.

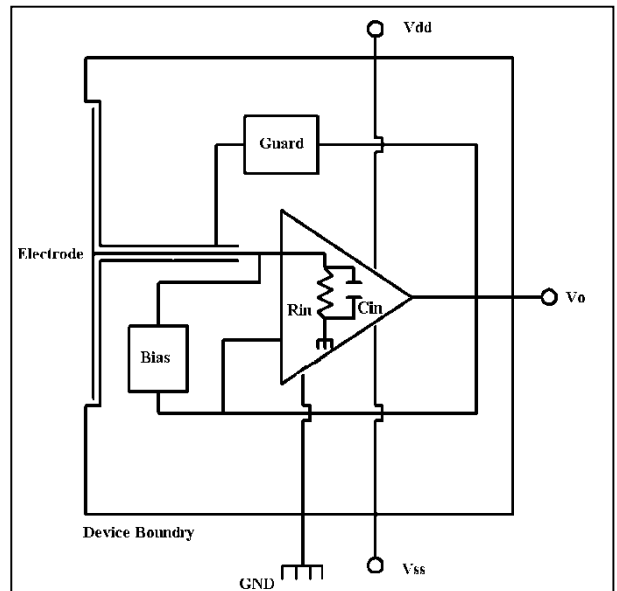

Fig. 2 Internal circuit of EPIC Movement Sensor

ELECTRICAL CHARACTERISTICS

$T_{amb} = -25^{\circ}\text{C}$ to $+75^{\circ}\text{C}$, $V_{dd}/V_{ss} \pm 2.4\text{V}$ to $\pm 5.5\text{V}$. The electrical characteristics are guaranteed by either production test or by design and characterisation. They apply within the specified ambient temperature and supply voltage unless otherwise stated.

| Characteristics | Value | | | Units | Conditions |
|---------------------------------------|-----------|------|-----------|------------|--|
| | Min. | Typ. | Max. | | |
| Supply voltage | ± 2.4 | | ± 5.5 | V | Bipolar supply, Gnd=0V |
| Supply current | 0.6 | 2.0 | 3.5 | mA | |
| Effective input resistance | | 20 | | G Ω | |
| Effective input capacitance | | 15 | | pF | As measured at the sensor electrode |
| Primary Output Voltage Gain (A_v) | 47.5 | 50 | 52.5 | | When measured with 250pF coupling capacitance. |
| Guard Output voltage gain | 0.95 | 1.0 | 1.05 | | @1kHz |
| Lower -3dB point | | 0.20 | | Hz | Set by internal DC signal rejection network – coupling capacitor 250pF |
| Upper -3dB point | 4.0 | | | kHz | |

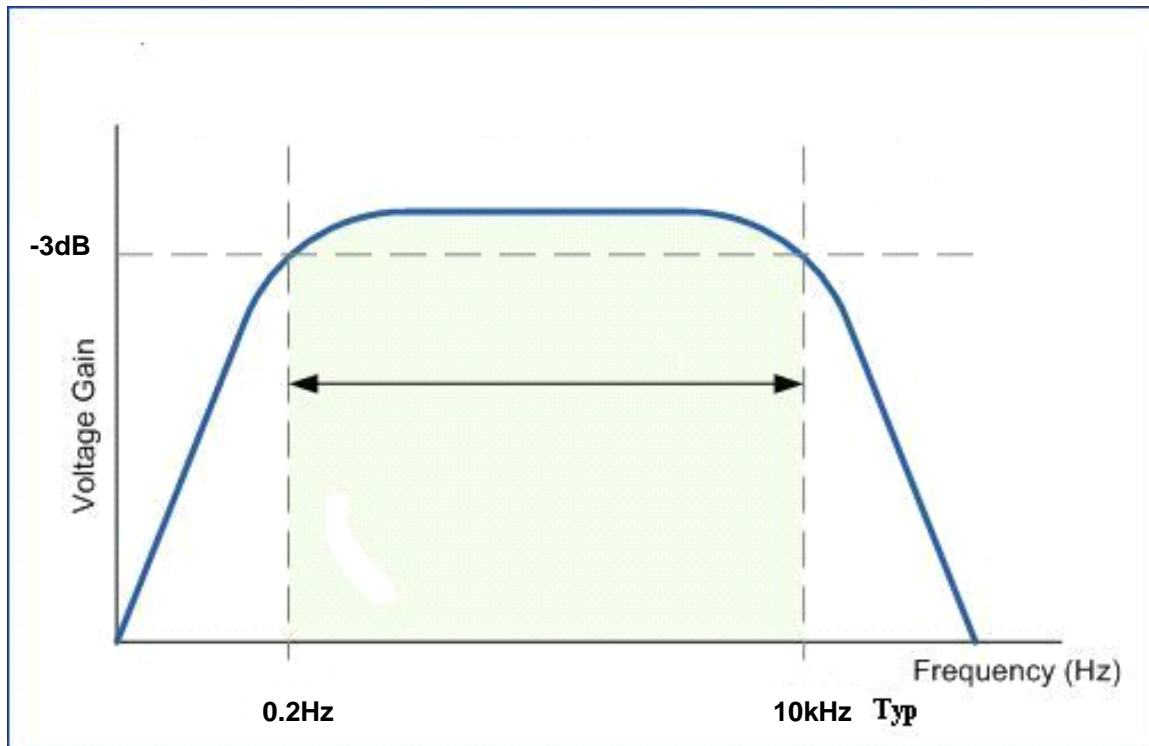

Fig. 3 Typical Bode Plot for PS25451 Sensor with Coupling through 250pF Capacitor

PIN ASSIGNMENT

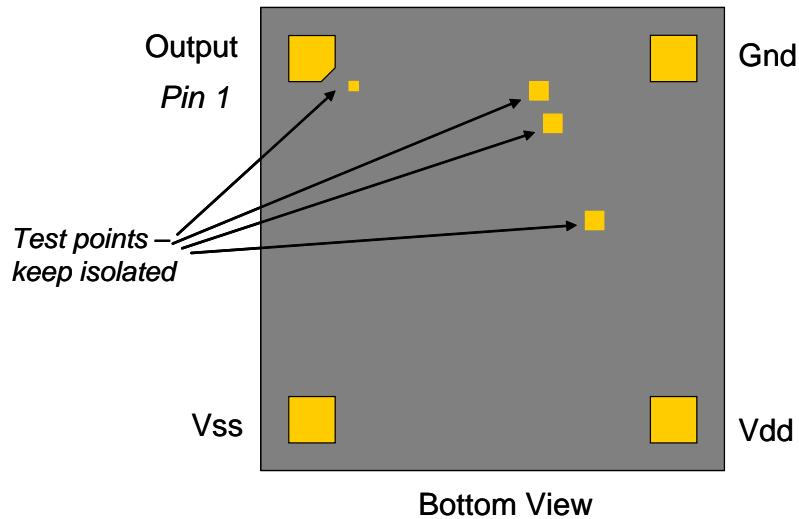
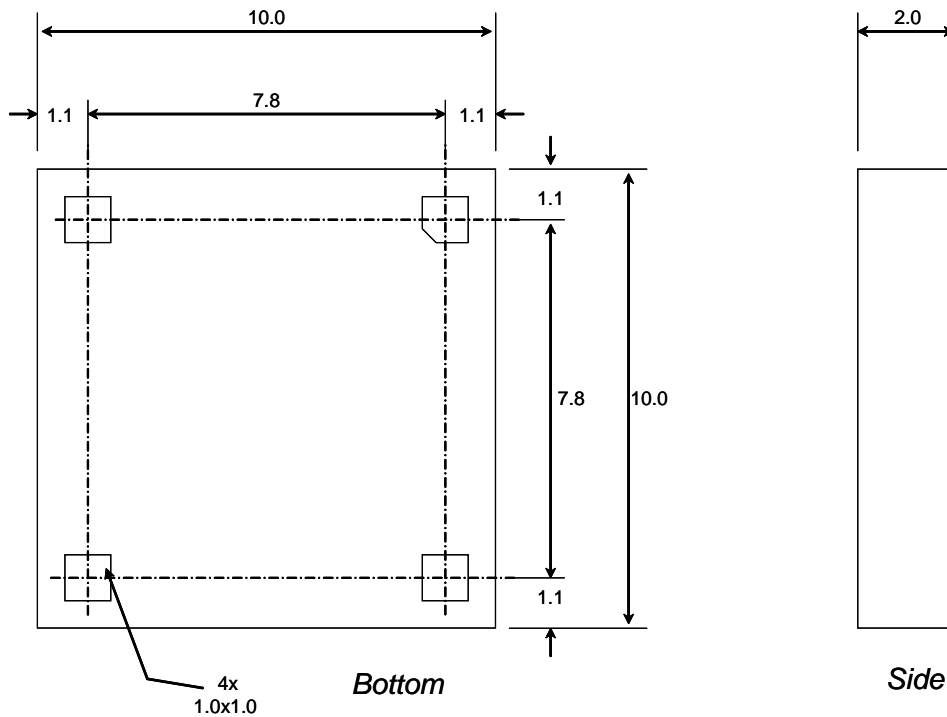

Fig. 4 Pin Assignment for the PS25451

MECHANICAL DIMENSIONS

A preliminary package diagram is shown below. This is certain to change and so should only be used for illustration purposes.



Mechanical Drawing (all dimensions are nominal and in mm)

ELECTROSTATIC DISCHARGE (ESD) PROTECTION

The PS25451 is manufactured using a high performance analog CMOS process. As for all CMOS components, it is essential that conventional ESD protection protocols be applied for the handling of this device.

5 Appendix B

- EPIC DEMO KIT
- Installation of EPS Evaluation Software

5.1 EPIC Demo Kit

Plessey PS25003 EPIC Demonstration Kit.



Demonstration Kit Standard Components

PS25003

- Control and interface box (CIB).
- Control and interface box software (download from website).
- USB cable.
- 2xPS25013 connector cables.
- Flying lead (2m long), 4mm plug to crocodile clip.
- Conductive sheet.

Demonstration Kit Sensor Options

The PS25003 is supplied with a choice of one of the following options:

- 2x PS25101 sensors, or
- 2x PS25102 sensors, or
- 2x Single channel demonstration boards with EPIC sensors*, or
- 1x Dual channel demonstration board with two EPIC sensors*

* Various EPIC sensors are available on these demonstrator boards.

User Guide Contents

1. Introduction.
2. The EPIC sensors.
3. The Control and Interface Box.
4. The Control and Interface Box Software.
 - 4.1 System Requirements
 - 4.2 Software Installation
 - 4.3 Software Use
 - 4.4 Software Shutdown
5. Example applications.
 - 5.1 Obtaining an electrocardiogram (ECG) signal
 - 5.2 Obtaining other physiological signals
 - 5.3 Non-contact ECG
6. TERMS and CONDITIONS

1 Introduction

The EPIC technology provides active electric potential sensors that may be used in a range of applications.

This demonstration unit comprises a pair of EPIC active sensors and a Control and Interface box (CIB). It is a flexible system that may be used to explore a range of applications from electrophysiological signal detection such as ECG (EKG) and EEG through to local electric field detection for applications such as motion sensing.

2 The EPIC sensors

The demonstration sets are supplied with either:

- 2x PS25101 sensors, or
 - 2x PS25102 sensors, or
 - 2x Single channel demonstration boards with EPIC sensors*, or
 - 1x Dual channel demonstration board with two EPIC sensors*
- * *Various EPIC sensors are available on these demonstrator boards*

PS25101 and PS25102: These are metal body sensors. Each is terminated by a 1.5m cable and a four pin DIN plug. The DIN plug attaches directly to the inputs of the PS25003 Control/Interface box. This sensor style is depicted below:



PS25101 or PS25102 Metal Body Sensor Showing Front and Back, Cable and Plug

The alternative sensor type to the metal body sensor is the so called 'Compact Sensor'. An example is shown in the images below:

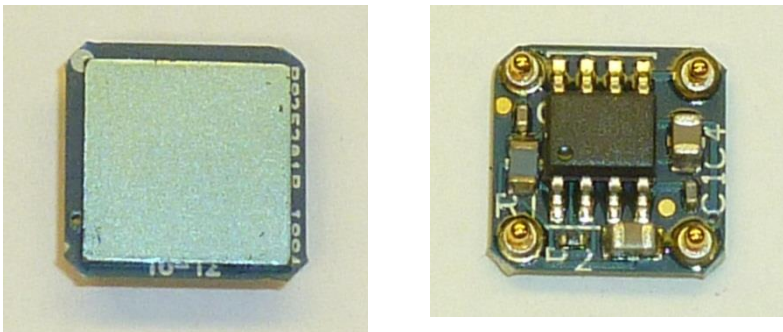

PS25201B Compact Sensor Showing Front and Back

These compact sensors are intended for surface mount in a finished system. This style of sensor is not directly suitable for connection to the Control/Interface Box and so these sensors are supplied on small demonstration boards that are terminated by a robust socket. Single channel and dual channel boards are available. The image below shows examples of these two board types:

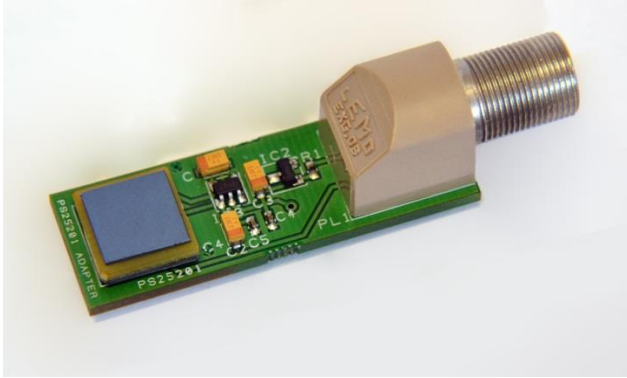

Single Channel Demonstration Board Carrying a Compact Sensor

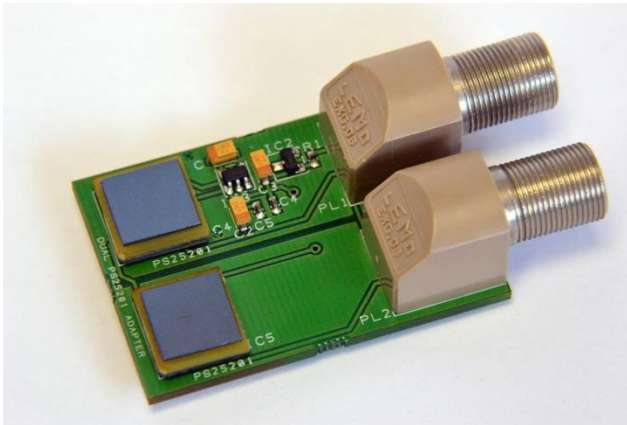

Dual Channel Demonstration Board Carrying Two Compact Sensors

The demonstration boards are connected to the Control/Interface Box by two PS25013 cables (supplied). These are terminated by a four pin DIN plug that attaches directly to the inputs of the PS25003 Control/Interface box.

The details of the sensors and demonstration boards is summarised in the table below:

5.2 Installation of EPS Evaluation Software

1. Introduction

The EPS evaluation software allows display, basic signal processing, and recording of EPS signals. Installation of software may take 10 to 20 minutes.

2. System Requirements

- A Windows based PC.
- A Spare USB port.
- Pentium 4 or greater processor.

3. Software Installation Instructions

Installation software is available from the Plessey FTP site or the Customer Portal*. If you need access, please contact Plessey Customer Care. Software can be provided on CD Rom, as ISO image or Memory Stick. If you prefer the EPS evaluation software available on CD or memory stick, please request a disc. If you want to download the software from the customer portal, please request an account from customer services.

1. From the Plessey FTP site, you will have access to the 'Sussexuni' Folder.
2. From here you will now see 'EPIC Sensor Demo V3.5'. Double Click to then access the Installer folder.
3. Once you have opened the Installer folder, double click on 'setup.exe' file.
4. You will be asked where you would like to install the software. I would always suggest accepting the default location. The default location should always install to your C Drive.
5. Once you have accepted the software agreement, click next and the EPS software will commence installation.
6. After the Installation is complete, a system reboot is strictly required.
7. When your computer returns to the desktop, connect the EPS control box to a spare USB port and run the EPS software.
8. If downloading from the Customer Portal, first extract files from EPIC Sensor Demo V3.5.zip and then follow steps 2 thru 7.

4. Uninstallation of Software

In order to remove the current or any previous version of EPS software, Open Control Panel and then double click on Add / Remove programs. You can see a list of all the programs installed on your PC.

- Click on 'EPS Demo for Labview 2010' and choose to remove.
- You will be asked if you are sure you would like to remove. At this point you would click 'Yes' to remove or 'No' to retain the program for later use.

6 Appendix C

- FAQ

6.1 FAQ

What is the gain of the EPIC sensor?

Currently the sensor is available with mid-range (flat-band) voltage gains of x10 or x50. This corresponds to around 20dB and 34dB.

What supply voltage do I need?

The PS252xx and PS254xx family (square compact) require a bipolar supply of between $\pm 2.5V$ and $\pm 4.5V$.

The PS25012x family of application boards generate the bipolar supply from a single supply, and so require only a unipolar supply of between +4 and +8V.

The PS251xx family of sensors require only a unipolar supply between +4.75 to +8.0V.

What is the current drain per sensor?

The PS252xx and PS254xx family (square compact) of sensors draw a supply current of around 2.5mA per sensor. Lower current versions of the compact sensor are in development.

The PS251xx draws higher supply current – around 4.5mA per sensor.

What is the output voltage?

The output of the PS251xx will swing between $\pm 2.5V$ full scale. For the PS252xx and PS254xx sensors it will swing between the supply rails.

What is the output resistance of the sensor?

From around 50 to 100 Ohms.

Why is the sensor output only showing mains frequency signals?

The EPIC sensor detects electric fields and, because the strongest electric field in the vicinity of the sensor is often from the 50Hz or 60Hz mains electricity supply that ambient noise is probably what will dominate the sensor's raw output. On 50x sensors that are not in contact with a subject, the mains frequency signal can swing from rail to rail.

For sensors with electrodes that are designed for contact sensing, the mains pick-up will reduce significantly when both the electrode and the system ground are touched.

Touching just the electrode with no ground will usually increase the mains noise as it couples through the body onto the sensor electrode. System ground contact is made by touching the metal case of PS25101 sensors or the plate on the back of the PS25012 application boards. Where sensors are used without applications boards, some means of touching the GND terminal should be provided if this method of reducing mains pick-up is being used. An alternative approach to reducing mains pick up is to employ a Driven Right Leg technique, as described in our application note Non-contact ECG measurement using EPIC.

As long as the signal is not limited by the supply rails, the required signals (e.g. ECG) can be extracted by a combination of filtering and common mode rejection (by differentially amplifying the output of two sensors). Mains frequency swings from rail to rail do not affect the ability of the sensors to detect movement, as motion will still cause a change in the measured signal. Suitable filtering should still be applied. In very noisy situations, or for measurement of non-contact electrophysiological signals, or for more sensitive movement sensing, the use of 10x gain sensors is recommended.

Is the EPIC sensor directional?

No. It senses through 360°, which makes it ideal for motion sensing. It is best viewed as something akin to a uni-directional microphone. A (very) small amount of forward sensitivity enhancement (really rear sensitivity reduction) can be obtained by placing a grounded metal plate behind the sensor.

Can EPIC sensors detect stationary fields or stationary objects perturbing that field?

The sensors are AC coupled (although the lower frequency point can be made almost arbitrarily low – typically a few tens of mHz) and so will only sense changes in the electric field. As long as one or more of the object, the sensors or the field (i.e. AC field), are moving then the object can be detected. There is no analogy to a DC baseline measurement for static field conditions.

Can EPIC be used for gesture recognition?

Yes. Currently we can accurately position a human hand placed between two sensors with an accuracy of better than 10% in one dimension and around 10% in two dimensions. We can track the movement of the hand in real time, which gives the option for recognising gestures with appropriate software. See also the next question, regarding tracking moving targets, which deals with movement and gestures in larger areas.

Can moving targets be tracked in 2D using "real time" algorithms?

Yes they can. The latest developments in software allow a single target to be tracked in real-time whilst moving around an area covered by four EPIC sensors. For example a room with one sensor placed in each of the upper corners. As the EPIC sensors track what is effectively the "centre of charge" it is not possible at the moment to track more than one object. With an array of sensors however we believe that this is possible.

More recent work suggests that monitoring the extant 50/60 Hz field may be a better approach for such applications (security related) and this is currently under development.

Can adults be distinguished from children?

No. A highly charged (electrically) child will look like a lowly charged adult. Moreover a child close to the sensors will appear similar to an adult standing further away.

What is the "range" of the EPIC sensor for motion sensing?

This depends on the charge on the target, the rate of motion and the local environmental conditions. It is best to think of the EPIC sensor as being characterized by its input referred noise and its gain rather than trying to describe a range. Adult humans can carry anywhere between zero and several thousand volts, depending on clothing and their surrounding environment. This can mean that a moving human target is detectable from say a metre worst case, up to several metres best case.

Recent developments suggest that maybe it is best not to measure perturbations in the quasi DC field but to use already existing AC fields that surround us in our normal day to day life. For example 50/60 Hz signals Using changes in the detectable signal strength amongst an array (or even between a pair) of electrodes it may be possible to locate targets at a greater range and with more reproducibility.

Can the EPIC sensor "see" through walls?

Yes – in some circumstances. If the sensor is placed close against an interior wall then it is possible (but not guaranteed) that electrical activity can be detected on the other side. If the wall contains metal or is in itself conducting then this may act as a Faraday Shield and render detection impossible.

Are the sensors affected by RF signals, such as those from mobile phones?

No. The upper frequency detected by currently available sensors is in the tens of kHz range. RF signals, including those from mobile phones are much higher than this and so do not disrupt the EPIC signal.

7 Appendix D

- Contact Information

7.1 Contact Information

7.1.1 Technical Support

Plessey has a Technical Support Centre to assist you with your technical questions about our products and applications. Our experts will provide you with accurate and prompt responses to your design-in and development needs.

To contact our experienced application engineers, please either email: technical.support@plesseysemi.com or Telephone +44 1793 518 042

Please provide a detailed description of your request. If you have a technical problem, please describe your application as fully as possible.

Plessey are developing an online technical support desk to further enhance our customer experience and to speed the resolution process. Details will be posted on the home page when available.

7.1.2 Plessey Locations

Plessey Semiconductors Ltd

Tamerton Road, Roborough, Plymouth, Devon
United Kingdom
PL6 7BQ

Plessey Semiconductors Ltd

Design & Technology Centre, Delta 500
Delta Business Park,
Great Western Way, Swindon
United Kingdom
SN5 7XE

Phone: Plymouth +44 1752 693000

Fax: Plymouth +44 1752 693200

Phone: Swindon +44 1793 518000

Fax: Swindon +44 1793 518030

Website: <http://www.plesseysemi.com>

7.1.3 Distributors & Reps

Please click on the following link, then select the Distributors and Reps tab on the bottom left hand side of the page for up to date information.

<http://www.plesseysemiconductors.com/contact.php>